

Advanced Test Products General Catalogue



PROMAX®



ROBINAIR®



LEAK DETECTION

ATP ZX-1A	4
TIF IR-1A	5
TIF XP-1A	6
TIF RX-1A	7
ATP-C1	8
TIF 8900-E	9
RA 16331	10
ACCESSORIES FOR RA 16331	11/12



RECOVERY UNITS

PROMAX RG 6-E	13
PROMAX RG 5410A-E	14
PROMAX MINIMAX-E	15
PROMAX RG 3000-E	16
RA 17801B	17
PROMAX CLK-1	18



SCALES / CHARGING

TIF 9000S	19
TIF 9030E	20
PROMAX ADS-100	21
TIF 9010A	22
TIF 9060S	23
TIF 9055	24



VACUUM PUMPS

ROBINAIR VACUUM PUMPS	25
RA 15401, RA 15601, RA 15121A	26
RA 15301-E, RA 15501-E	27
ROBINAIR ACCESSORIES FOR VACUUM PUMPS	28



VACUUM GAUGES

RA VG-1	30
RA VG-64	31
RA 14777, RA 14010A	32



MANIFOLDS / GAUGES / HOSES

ROBINAIR MANIFOLD SETS	33-35
DIGITAL GAUGES	36/37
ANALOG GAUGES	38
REPLACEMENT PARTS FOR MANIFOLDS	39
ROBINAIR REFRIGERANT CHARGING HOSES, ROBINAIR HOSE SELECTION CHART	40
ROBINAIR SPECIAL HOSES	41
ROBINAIR ACCESSORIES, REPLACEMENT PARTS, VALVES, COUPLERS FOR HOSES	42-47
PRESSURE REGULATORS NITROGEN, CO ₂ , HYDROGEN	48-50
CONDENSATE PUMPS	51-53



GENERAL TOOLS / OPTIONAL ACCESSORIES

FITTINGS Bright Flair Fittings	55/56
TUBE TOOLS	57-62
TUBE BENDERS	63-67
FLARING / SWAGING TOOLS	67-72
DEBURRING TOOLS	73
RATCHET WRENCHES	74
ROBINAIR VALVE TOOLS	75/76
ROBINAIR VALVE CORES	76
ROBINAIR FITTINGS	76
GENERAL TOOLS	77/78



DIAGNOSTIC

ELECTRICAL TEST AND MEASUREMENT	79-85
TEMPERATURE MEASUREMENT	86-90
DIAGNOSTIC INSTRUMENTS	91-95
OTHER	96



GENERAL TECHNICAL INFORMATION

PROMAX RG 6-E PARTS LIST	97
PROMAX RG 5410A-E PARTS LIST	98
PROMAX MINIMAX-E PARTS LIST	99
PROMAX RG 3000-E PARTS LIST	100
ROBINAIR COOLTECH™ VACUUM PUMPS PARTS LIST	101
VACUMASTER™ VACUUM PUMPS PARTS LIST	102
REFRIGERANT LEAK DETECTOR REPLACEMENT SENSOR TIPS AND FILTERS	103



APPENDIX

PRESSURE TEMPERATURE GUIDE	104
TEMPERATURE AND PRESSURE UNITS, CONVERSION FACTORS	105
PRODUCT INDEX	106/107

LEAK DETECTION



RECOVERY UNITS



SCALES / CHARGING



VACUUM PUMPS



VACUUM GAUGES



MANIFOLDS / GAUGES / HOSES



GENERAL TOOLS / ACCESSORIES

Manifolds, Fittings, Tube cutters, Tube benders, Other



DIAGNOSTIC

Electrical Meters, Thermometers, Anemometers, Other



GENERAL TECHNICAL INFORMATION



APPENDIX



ATP ZX-1A

Heated Pentode™ Refrigerant Leak Detector



ATP ZX-1A



ATP ZX-1A with carrying case

Refrigerants

CFC	e.g. R12
HCFC	e.g. R22, 502
HFC	e.g. R134a, 404a, 125, 410A
Replacements	e.g. AZ-50, HP 62, MP 39, R1234yf, R32

Features

- Patented Heated Pentode™ Sensor technology
- Refrigerant specific detection
- Elimination of false alarms
- Unaffected by rapid temperature change
- Sensor cannot be "poisoned" by excessive refrigerant
- Detects ALL halogenated refrigerants, including R32
- Sensitivity less than 3 g/year
- True mechanical pump provides instant response and clearing
- Tri-color visual leak size indication
- Tactile keypad controls
- Adjustable sensitivity and one touch reset
- Mute feature silences audible alarm
- Sensor status indication
- Battery self test
- 40 cm (16") flexible probe
- Hard carrying case and battery charger included
- Certified to SAE J2913 / SAE J2791 / E-35422 / EN 14624
- CE approved
- Two year warranty

Specifications

Ultimate Sensitivity	< 3 g/year (0.1 oz/year) for all refrigerants
Power Supply	Nickel-Metal Hydride, (Ni-MH) Rechargeable Battery Pack
Battery Life	Ni-MH (6 to 8 hours)
Sensor Life	100 to 150 hours
Operating Temp	-20 °C to 50 °C

Replacement Parts

Heated Pentode™ Sensor	TIF ZX-2
230 V / 50 Hz Battery Charger	TIF ZX-3E
Nickel-Metal Hydride (NiMH) Battery Pack	TIF ZX-20
Flexible Probe (includes Filter and Tip)	TIF ZX-10
Filter	TIF ZX-15
Hard carrying case	TIF ZX-25
Remote Battery Charging Base	TIF ZX-6
12 V DC Battery Charger (cigarette lighter style)	TIF ZX-11
Filter and Tip	TIF ZX-14

TIF IR-1A

Infrared Refrigerant Leak Detector



TIF IR-1A

Features

- Advanced infrared sensor, designed for years of use
- Three sensitivity levels allow detection down to 3 g/year
- Automatically recalibrates in highly contaminated areas to help pinpoint the exact location of the leak
- Won't trigger on oil or moisture
- Senses CFC, HFC, HCFC, HFO1234yf and R32
- 8-hour re-chargeable lithium Ion battery lasts all day long and beyond
- Visual alert makes it easy to find leaks in noisy environments
- Audible alert with mute button
- Durable carrying case allows you easily store leak detector and accessories
- Certified to SAE J2913 / SAE J2791 / E-35422 / EN 14624

Specifications

Refrigerants	CFC, HFC, HCFC, HFO1234yf and blends
Sensing element	Infrared
Response time	Less than 1 second
Sensitivity levels	HIGH 3 g/year and higher MEDIUM 7 g/year and higher LOW 14 g/year and higher
Accuracy	Meets current EN14624 standards
Reset	Automatic
Warm up time	30 seconds
Probe length	38 cm
Battery type	3.7 V DC (nominal) rechargeable, lithium ion, polymer battery
Battery life	Approximately 8 hours when fully charged.
Warranty	One Year

Refrigerants

CFC	e.g. R12
HCFC	e.g. R22, 502
HFC	e.g. R134a, 404a, 125, 410A
Replacements	e.g. AZ-50, HP 62, MP 39, R1234yf, R32

Replacement Parts

100-240 V AC Wall Charger	TIF IR-2
Extension Probe (23 cm)	TIF IR-4
Rigid Extension Probe	TIF IR-5
12 V DC Charger	TIF IR-7
Lithium-Ion Battery	TIF IR-9
EU Plug Adapter	TIF IR-10
GB Plug Adapter	TIF IR-11
Maintenance Kit: Filters (10) and O-rings (5)	TIF IR-12



TIF XP-1A

Refrigerant Leak Detector



TIF XP-1A

Features

- Microprocessor controlled circuit with Advanced Digital Signal Processing, monitors the sensing tip up to 2000 times per second
- Detects all halogenated refrigerants, including R32
- Variable frequency audible alarm
- 14" Flexible stainless steel probe with Teflon™ liner
- Rubber cushion grip
- Constant power indication
- Power supply 3 V DC, two "C" cell alkaline batteries (included)
- Sensing tip life: approx. 20 hours (two tips included)
- Operating temp. -20° to 52° C
- Blow molded carrying case included, optional holster
- Certified to SAE J2913 / SAE J2791 / E-35422 / EN 14624
- UL Classified and CE approved
- Two year warranty

Refrigerants

CFC	e.g. R12
HCFC	e.g. R22, 502
HFC	e.g. R134a, 404a, 125, 410A
Replacements	e.g. AZ-50, HP 62, MP 39, R1234yf, R32

Specifications

Ultimate Sensitivity	< 3 g/year (0.1 oz/year)
True Mechanical Pump	Yes
Visual Leak Indication Levels	18 (tri-color)
Sensitivity Levels	7
One Touch Reset and Keypad Controls	Yes
Mute Button	Yes
Battery Test	True voltage indication
Battery Life	Approx. 30 hours

Replacement Parts

Hard carrying case	TIF XP-4A
Cover for battery compartment	TIF XP-5A

Optional Accessories

Maintenance Kit (3 Tips with protectors)	TIF XP-2
--	----------



TIF RX-1A

Refrigerant Leak Detector



TIF RX-1A

Refrigerants

CFC	e.g. R12
HCFC	e.g. R22, 502
HFC	e.g. R134a, 404a, 125, 410A
Replacements	e.g. AZ-50, HP 62, MP 39, R1234yf, R32

Features

- Microprocessor controlled circuit with Advanced Digital Signal Processing, monitors the sensing tip up to 2000 times per second
- Detects all halogenated refrigerants, including R32
- Variable frequency audible alarm
- 14" Flexible stainless steel probe with Teflon™ liner
- Rubber cushion grip
- Constant power indication
- Power supply: 3 V DC, two "C" cell alkaline batteries (included)
- Sensing tip life: approx. 20 hours (two tips included)
- Operating temp: -20° to 52° C
- Blow molded carrying case included, optional holster
- Certified to SAE J2913 / SAE J2791 / E-35422 / EN 14624
- UL Classified & CE approved
- Two year warranty

Specifications

Ultimate Sensitivity	< 5 g/year (0.25 oz/year)
True Mechanical Pump	Yes
Visual Leak Indication Levels	6 (single color)
Sensitivity Levels	2
One Touch Reset and Keypad Controls	Yes
Mute Button	n/a
Battery Test	n/a
Battery Life	Approx. 30 hours

Replacement Parts

Hard carrying case	TIF XP-4A
Cover for battery compartment	TIF XP-5A

Optional Accessories

Maintenance Kit (3 Tips with protectors)	TIF XP-2
--	----------



ATP-C1 CO₂ Leak Detector



ATP-C1

The ATP-C1 Carbon Dioxide Gas Leak Detector is the most technologically advanced of its kind. The fully automatic ATP-C1's low power requirements, small size and high sensitivity combine to create a tool which is easy to handle and ultra effective at locating even the most difficult-to-find leaks. The ATP-C1's long life sensor will detect concentrations of carbon dioxide gas as low as 400 ppm over ambient. False alarms are eliminated due to its high selectivity. The ATP-C1 is excellent for servicing carbon dioxide refrigeration systems or any general purpose leak detection application where compressed carbon dioxide can be used as the test gas.

Features

- Lightweight, ergonomic design
- Simple, one button operation
- Two sensitivity modes, enabling quick and easy location of large and small leaks
- Sturdy blow-molded carrying case
- Both visual and audible leak detection signal
- Low battery indicator
- Automatic power-off to conserve battery life
- One year warranty

Specifications

Weight	425 g
Batteries	4 x 1,5 V „AA“ Alkaline Batteries (6 V DC)
Battery Life	20 hours
Sensitivity	High: Less than 400 ppm over ambient
	Low: Less than 4000 ppm over ambient
Sensor Life	> 2 years
Operating temperature	0° to 50 °C
Warm up time	10 seconds
Calibration	automatic
Response time	1 second
Reset time	1 second
Probe length	12" (30 cm)

Replacement Parts

Replacement sensor	ATP-C2
--------------------	--------



TIF 8900-E

Combustible Gas Detector



TIF 8900-E

Features

- Solid state sensor technology, long life and precision
- Broad band of combustible gas detection including R290, 600, 600a
- Sensitivity as low as 5 ppm
- Adjustable sensitivity
- Audible "Geiger counter" signal
- LED Leak Intensity Lights
- Automatic warm up
- Cordless operation
- Flexible 40 cm stainless probe for hard to reach places
- Rechargeable battery and charger included
- Rugged custom carrying case
- UL and CE approved
- One year warranty

Applications

- Trace Gas N₂ (95 %) H₂ (5 %)
- Gas lines and pipes
- Exhaust and fuel leaks
- Propane filling stations
- Fuel in marine bilges
- Heat Exchanger leaks
- Check manholes for safety
- Detect arson residue
- IAQ tests
- Liquid or gas fired heating systems

Specifications

Battery Charger	230 V / 50 Hz
Probe Length	40 cm (16")
Power Supply	2 x 2.4 V Batteries
Battery Life	4 Hours / Charge
Response Time	Instantaneous
Warm-up Time	30 seconds
Operating Temp	0 °C to 52 °C (32 °F to 125 °F)

Sensitivity

Acetylene	50 ppm
Iso-Butane (R600a)	500 ppm
Methane	500 ppm
Ethane (R170)	500 ppm
Propane (R290)	500 ppm
Ethylene	500 ppm
Hydrogen	500 ppm
Methyl Ether	500 ppm
Vinyl Chloride	5 ppm
Methyl Chloride	5 ppm
Hydrogen Sulfinde	5 ppm
Acetone	50 ppm
Methanol	50 ppm
Ammonia (R717)	20 ppm
Gasoline	1 ppm
Chlorine	1 ppm

Replacement Parts

Sensor	TIF 8801
Rechargeable batteries (2 each)	TIF 8806A
230 V battery charger	TIF 8806B
Carrying case	ATP-7038
Battery Cover	527690RED



RA 16331

UV Leak Detection, HVAC/R Dye Kit



RA 16331

Features

- Cordless UV light
- Injector
- 6 dye cartridges
- Charger 230 V, 50 Hz
- UV glasses
- Connecting hose (1/4" FFL)
- "Date installed" labels
- Dye cleaner
- Protective carrying case
- Great for pinpointing those exclusive hard to find leaks
- Super bright cordless, rechargeable UV light
- Drop/shock proof light – produces NO heat
- Universal HVAC/R dye cartridges – compatible with ALL lubricants & refrigerants
- Compact injector and cartridgesystem – pre-measured: No mess or waste
- For all ester and mineral oils

Specifications

Battery Type	Nickel Metal Hydride - rechargeable
Battery Life/Charge	3 hours of continuous use
UV LED working life	100,000 hours



RA 16332 Injector Kit

Replacement Parts

UV Light, LED - Rechargeable (includes 230 V charger)	RA 16353
Injector Gun	RA 16339
Charger, 230 V / 50 Hz	RA 16349
Hose, replacement	RA 16340
Replacement Dye Cartridges, 7,5 ml (1/4 oz/6 ea)	RA 16336
Replacement Dye Cartridges, 15 ml (1/2 oz/6 ea)	RA 16337
Replacement Dye Cartridges, 22,5 ml (3/4 oz/6 ea)	RA 16338
Labels, "Date Installed"	RA 16333
Dye Cleaner, 940 ml (32 oz) Bottle	RA 16263
Glasses, UV	RA 16257

Optional Accessories

Dye Injector Kit - HVAC R	RA 16332
---------------------------	----------

ACCESSORIES FOR RA 16331

ROBINAIR®

RA 16356

RA 16356 Universal UV Dye Cartridges

Features

- Accurate detection of leaks in refrigeration systems
- Four Refrigerant Dye cartridges, 30 ml (1 oz) content each
- Sufficient for 20 applications
- Includes service stickers



RA 16353

RA 16353 True UV Leak Detection Light

Features

- Cordless and Rechargeable true UV LED Light
- UV enhancing glasses
- Battery charger 230 V / 50 Hz included

Specifications

Battery Type	Nickel Metal Hydride - rechargeable
Battery Life/Charge	3 hours of continuous use
UV LED working life	100,000 hours

CE

i

ACCESSORIES FOR RA 16331

Dye Cartridges

ROBINAIR®

RA 16336

RA 16336

Dye Cartridges for systems containing up to 2,2 kg of refrigerant

Features

- 6 Cartridges 7,5 ml (0,25 oz)
- For medium systems: Residential systems up to 2,2 kg (4,9 lbs) of refrigerant or up to 1,5 l (1,6 qt) of oil
- For all ester and mineral oils
- For RA 16331, RA 16332



RA 16337

RA 16337

Dye Cartridges for systems containing 2,3 to 4,5 kg of refrigerant

Features

- 6 Cartridges 15 ml (0,5 oz)
- For medium-large systems: Light commercial & large residential systems 2,3 to 4,5 kg (5 to 9,9 lbs) of refrigerant or 1,6 to 3,0 l (1,7 to 3,2 qt) of oil
- For all ester and mineral oils
- For RA 16331, RA 16332



RA 16338

RA 16338

Dye Cartridges for systems containing 4,6 to 11,4 kg of refrigerant

Features

- 6 Cartridges 22,5 ml (0,75 oz)
- For large systems: Commercial & light industrial, including all split 4,6 to 11,4 kg (10 to 25 lbs) of refrigerant or 3,1 to 7,6 l (3,3 qt to 2 gal) of oil
- For all ester and mineral oils
- For RA 16331, RA 16332

RG 6-E

Twin Cylinder Refrigerant Recovery Unit



RG 6-E

Promax introduces its new Twin Cylinder design RG 6-E – with best in class recovery rates on all refrigerants. Using the proven Promax Oil-less compressor design, we have developed a special twin cylinder version which permits faster recovery under all conditions. Paired with an all-new 1 HP / 735 W motor – this design provides better throughput in all conditions. Packaged in a new housing with new features, the RG 6-E out-performs all competitors, but remains lightweight and compact. Specifically designed for high pressure refrigerants like R410A and new replacement azeotropes, the RG 6-E will meet your needs well into the future.

Features

- Our fastest ever Recovery Machine
- New Patent Pending design
- Twin cylinder Oil-less compressor increases recovery rates while keeping weight and size down.
- 1 HP / 735 W direct drive motor
- Recovers all commonly used CFC, HCFC and HFC refrigerants, including R410A
- High Pressure Safety cut-off switch
- Vacuum cut-out switch enables selectable low pressure “cut-off”
- Very low noise and vibration
- Rubberized padded over-molded handle
- Clear, easy-to-read pressure gauges
- Self Purge feature included
- Integrated Inlet Filter Screen
- Corrosion proof injection molded plastic housing
- Power Source – 230 V / 50/60 Hz
- Available 115 V / 60 Hz
- Includes 2.5 m removable power cord with universal IEC connector
- CE, UL and ARI Approvals
- Field Serviceable
- Weighs only 14.5 kg
- Dimensions: 432 x 305 x 228 mm



Twin Cylinder Compressor

International Version

UK, 115 V / 60 Hz	RG 6-E 115 V / 60 Hz
-------------------	----------------------

Replacement Parts

Filter Drier (1/4" MFL x 1/4" MFL)	100343
Hose, Blue 10 cm (4")	100345
Inlet Fitting with filter screen	SK-6001

Optional Accessories

14 kg (30 lbs) Recovery Tank	RGT30NS
23 kg (50 lbs) Recovery Tank	RGT50NS



1 HP / 735 W



RG 5410A-E

High Pressure Recovery Unit



RG 5410A-E



CP1320

PROMAX "oil-less" compressor "CP1320"

Features

- Recovers all commonly used CFC, HFC, HCFC refrigerants including R410A
- Designed for use with high pressure refrigerants
- High Pressure safety "cut off" switch 38,5 bar (550 psi)
- Proprietary "oil-less" compressor capable of handling both liquid and vapor refrigerants
- All new ergonomic design for easier handling
- 3/8" – 3-row condensor for maximum performance in even the hardest conditions
- VAC Sensor Select, selectable low pressure ON/OFF switch
- New Generation Compressor, new valves and piston
- 2,5 m removable cable
- Manual reset high pressure switch
- Corrosion proof polyethylene blow molded case
- Field serviceable semi-hermetic compressor
- Self purge feature
- Includes filter-drier
- Power source – 230 V 50/60 Hz
- Available 115 V / 60 Hz
- CE, UL, ARI and TÜV Approvals
- Weight: 13,5 kg
- Dimensions: 325 x 245 x 485 mm

International Version

UK, 115 V / 60 Hz	RG 5410A-E 115 V / 50/60 Hz
-------------------	-----------------------------

Replacement Parts

Oil-separator (only Minimax + RG 5410)	100911
Filter-Drier, 1/4" MFL x 1/4" MFL	100343
Hose, Blue 10 cm (4") Long	100345
Inlet Fitting with filter screen	SK-6001

Optional Accessories

14 kg (30 lbs) Recovery Tank	RGT30NS
23 kg (50 lbs) Recovery Tank	RGT50NS



MINIMAX-E

High Pressure Recovery Unit

PROMAX®



MINIMAX-E

Features

- Recovers all commonly used CFC, HFC, HCFC refrigerants including R410A
- Minimum size – maximum performance; ideal for residential and appliance service
- Designed for use with high pressure refrigerants
- 38,5 bar (550 psi) safety cut off switch
- Proprietary “oil-less” compressor capable of handling both liquid and vapor refrigerants
- Ergonomic design for easier handling
- Tough corrosion proof polyethylene blow molded case
- Self purge feature
- Includes filter-drier
- 2,5 m removable cable
- Power Source – 230 V / 50/60 Hz
- Available 115 V / 60 Hz
- CE, UL, ARI and TÜV Approvals
- Weight 11 kg
- Dimensions 250 x 222 x 406 mm (11" x 9" x 16")

International Version

UK, 115 V / 60 Hz

Minimax 115 V / 50/60 Hz

Replacement Parts

Oil-separator (only Minimax + RG 5410)	100911
Filter-Drier, 1/4" MFL x 1/4" MFL	100343
Hose, Blue 10 cm (4") Long	100345
Inlet Fitting with filter screen	SK-6001

Optional Accessories

14 kg (30 lbs) Recovery Tank	RGT30NS
23 kg (50 lbs) Recovery Tank	RGT50NS



CP1320

PROMAX “oil-less”
compressor “CP1320”

CE TÜV  



RG 3000-E

Refrigerant Recovery Unit



RG 3000-E

ONLY 8 kg

Promax introduces the lightest recovery machine on the market today. The all-new RG 3000-E weighs only 8 kg, less than any recovery machine and many vacuum pumps! However, performance is not sacrificed by small size, recovering both vapor and liquid at world-class rates.

Features

- World's smallest Full Featured Refrigerant Recovery Machine
- Weighs only 8 kg!
- Volumetric size is just 50 % of our previous smallest unit
- Recovers all commonly used CFC, HCFC and HFC refrigerants, including R410A
- High Pressure Safety cut-off switch
- Simple 2 valve controls
- Clear, easy-to-read pressure gauges
- Proprietary Oil-Less compressor recovers both liquid and vapor
- Self purge feature
- Includes filter-drier
- Corrosion proof injection molded plastic housing
- High efficiency cross flow fan/condensor layout
- Power source – 230 V 50 Hz
- Available 115 V / 60 Hz
- Includes 2.5 m (8 ft) power cord with universal IEC connector
- CE, UL, ARI and TÜV Approvals
- Multiple International Patents Pending
- Dimensions: 310 x 235 x 175 mm

International Version

UK, 115 V / 60 Hz	RG 3000-E 115 V / 60 Hz
-------------------	-------------------------

Replacement Parts

Filter-Drier, 1/4" MFL x 1/4" MFL	100343
Hose, Blue 10cm (4") Long	100345
Inlet Fitting with filter screen	SK-6001

Optional Accessories

14 kg (30 lbs) Recovery Tank	RGT30NS
23 kg (50 lbs) Recovery Tank	RGT50NS



RA 17801B

Refrigerant Recovery, Recycle, Evacuate and Recharge Machine



RA 17801B

Features

- Recovers, Recycles, Evacuates and Recharges
- Continuous operation – all through one hook up
- In-plant maintenance – Ideal for departments that use different types of refrigerants for various systems
- Multiple Refrigerants – R12, R134a, R22, R500, R502, MP and HP Blends – and many more
- Microprocessor controlled functions prompt you through programming and signal preventative maintenance
- Float Chamber – Automatically adjusts from liquid to vapor for most efficient recovery
- Electronic Scale – Makes it simple to recharge to factory specifications; also weighs recovered refrigerant and provides tank overflow protection
- Cooltech™ Vacuum Pump – 6 CFM, has the capacity to thoroughly evacuate system
- Lockout Panel – Prevents mixing of refrigerants; slides to one side for 1/4" fittings and to the other for 1/2" ACME fittings
- Single Pass Recycling – Makes an initial pass through the filter-drier; additional recycling can be programmed in case of compressor burn-out, or other conditions
- Heavy Duty Filter-Drier – Removes moisture and acid from the refrigerant; can handle up to 136 kg (300 lbs) between changeovers
- Supplied with two 23 kg (50 lbs) tanks; one with 1/4" fittings and the other with 1/2" ACME fittings
- Includes three sets of hoses – Two sets for refrigerants using 1/4" SAE fittings and one set with R134a field service couplers
- Power Supply 230 V / 50 Hz
- Design certified by UL to meet SAEJ-1770

International Version

115 V / 60 Hz readout in lbs	RA 17800B
------------------------------	-----------

Replacement Parts

Recycling Filter-Drier	RA 19776
23 kg (50 lbs) Refillable Tank 1/4" fittings	RA 17506
23 kg (50 lbs) Refillable Tank 1/2" ACME fittings	RA 34750



PROMAX CLK-1

Refrigerant Cleaning / Recycling Kit

PROMAX[®]

Features

- Specifically designed to Clean and Recycle refrigerant On-Site in the field
- Ideal for R22 applications where new refrigerant is no longer available
- Removes dirt, moisture and oil from refrigerant as it is transferred from a refrigeration system
- High capacity proprietary oil separator removes 95 % + of oil entrained in refrigerant vapor and permits collection and measurement of removed oil
- Includes moisture indicating sightglass to monitor refrigerant flow and indicate when a drier replacement is needed
- High performance filter/drier removes moisture and contaminants
- Unique and convenient nylon "pouch" package allows flexibility, portability and ease of use and transport - Lightweight and fully portable
- Can be used with all CFC/HCFC or HFC refrigerants, including high pressure compounds such as R410A
- Equipped with 1/4 turn shut off valves to control flow and isolate cleaning kit when not in use
- Filter/drier is easily replaced in the field, and permits use of different size filters depending on application
- Can be used with any recovery machine or refrigerant system
- Convenient hanging hook included
- Dimensions 320 x 270 x 80 mm
- Weight 1.75 kg

TIF 9000S

Dual Range Compact Refrigerant Scale 50 kg/2 g and 100 kg/4 g



TIF 9000S

Now get the high accuracy you need for critical low volume charges without sacrificing the high weight capacity you need for bigger jobs. The TIF9000S dual range refrigerant scale offers you the ability to choose your range and resolution to best suit the job you are doing today. Add in a backlit display, auto-off timer and the extra large platform that can accommodate cylinders as large as 35 cm diameter and you have more features than you can measure!

Features

- Dual range scale; User selectable 2 g resolution/ 50 kg capacity or 4 g resolution with 100 kg capacity
- Extra large display with built-in backlight
- Auto-shut off feature saves battery life when unit is not in use, selectable
- Built-in platform mount for small cylinder charging (optional fittings available)
- Additional user selectable functions
- Extra large platform 250 x 250 mm, fits 350 mm diameter cylinder
- Integrated carrying handle
- Powered by a single 9 V battery
- Touch Key controls
- User selectable scale: kg, lbs, oz, decimal lbs
- Carrying bag included for protection and convenience
- Mechanical overload protection
- CE approved
- One year warranty



Mounting for small cylinders



Nylon carrying case

Specifications

Ranges	High Resolution Mode: 0 kg - 50 kg 0 lbs 0 oz - 110 lbs 4 oz / 0.00 lbs - 110.25 lbs
	Low Resolution Mode: 0 kg - 100 kg 0 lbs 0 oz - 220 lbs 0.0 oz / 0.00 lbs - 220.000 lbs
Resolution	High Resolution Mode: 2 g/0 lbs 0.1 oz/0.004 lbs
	Low Resolution Mode: 4 g/0 lbs 0.1 oz/0.009 lbs
Accuracy	±0.5% of reading ±1 digit
Display	Extra Large 76 x 30 mm Backlit Liquid Crystal Display, with 17 mm characters
Platform Dimensions	250 x 250 mm
Power Supply	One 9 V alkaline battery



Battery	Life 20 hours (approx.)
Operating Temperature	-10 °C to 49 °C
Dimensions	435 x 320 x 58 mm
Included accessories	Battery and nylon carrying case
Weight	4 kg



TIF 9030E

Compact Refrigerant Scale up to 100 kg



TIF 9030E

Features

- Range up to 100 kg
- Display weight in kg, oz, lbs
- Resolution 10 g
- Easy to use:
ON/OFF - UNITS - ZERO buttons
- 9 V battery operated
- Overload protected
- CE approved
- One year warranty

Specifications

Range	0 kg to 100 kg or 0 lbs 0oz to 199 lbs 15 oz or 0.00 lbs to 199.99 lbs
Resolution	0.01 kg or 0.05 lbs
Accuracy	±0.5 % of reading ±1 digit
Power Supply	One 9 V alkaline battery
Battery Life	20 hours (approx.)
Operating Temperature	-10 °C to 49 °C
Weight	2.36 kg
Dimensions	304.8 x 431.8 x 57.1 mm
Standard accessories	Battery and nylon carrying case



Nylon carrying case



PROMAX ADS-100

"Slimline" Refrigerant Scale up to 100 kg

PROMAX®



PROMAX ADS-100

A revised and updated version of the classic TIF Slimline scale, the PROMAX ADS-100 brings greater performance, reliability and usability. With outstanding resolution, and no compromise on capacity, this unit offers features and specs that you won't want to do without.

Features

- 100 kg or 200 lbs capacity
- Three display modes in Kilograms, lbs/oz, Decimal Pounds
- Very high resolution: 4 g / 0.2 oz / 0.010 lbs
- Compact design and completely portable
- Extreme accuracy
- Auto Zero
- Removable platform and control box with prop stand/hanging hook
- Overload protected
- CE approved
- Two year warranty

Specifications

Range	0 kg to 100 kg, or 0 lbs 0.0 oz to 199 lbs 15.8 oz, or 0 lbs to 199 lbs
Resolution	4 g / 0.2 oz / 0.010 lbs
Accuracy	±0.5 % of reading ±1 digit
Operating Temperature	-10 °C to 49 °C
Power Supply	1 x 9 V Alkaline battery
Battery Life	20 hours
Coil Cord Length	1,8 m (6 ft)

CE



TIF 9010A

"Slimline" Refrigerant Scale up to 50 kg



The TIF 9010A brings greater performance, reliability and usability. With the greatest resolution in the industry, and still outstanding capacity range this unit offers features and specs that you won't want to do without.

Features

- 50 kg / 110 Pound capacity
- Three display modes – Kilograms, lbs/oz, Decimal Pounds
- Very High Resolution 2 g / 0.1 oz / 0.005 lbs
- Extreme Accuracy
- Auto Zero
- Removable platform and control box with prop stand/hanging hook
- Compact design, completely portable
- Overload protected
- CE approved
- Two year warranty

Specifications

Range	0 kg to 50 kg, or 0 lbs 0.0 oz. to 110 lbs 0.0 oz, or 0 lbs to 110 lbs
Resolution	2 g / 0,1 oz / 0,005 lbs
Accuracy	±0.5 % of reading ±1 digit
Operating Temperature	-10 °C to 49 °C
Power Supply	9 V Alkaline battery
Battery Life	20 hours
Coil Cord Length	1,8 m (6 ft)



TIF 9060S

Heavy Duty Aluminium Scale up to 150 kg



TIF 9060S

Features

- Maximum capacity 150 kg
- 6 digit LCD readout
- Easy to handle
- Three units to select from kg, lbs, lbs/ozs
- Resolution 10 g, 0,02 lbs and 0,5 oz
- Low Battery indicator (<7.5 V DC)
- Platform 350 x 260 mm
- Overload protected
- Includes nylon carrying case
- CE approved
- One year warranty

Specifications

Range	0.00 kg to 150.00 kg
Resolution	10 g / 0.02 lbs / 0.5 oz
Power Supply	1 x 9 V alkaline battery
Round object max.	Ø 340 mm
Function	On/Off, Zero, Units
Temperature range	-10 °C to 50 °C
Accuracy	±0.5 % of reading ±1 digit
Dimensions	260 x 350 x 53 mm
Load Platform	Anodized aluminium



Nylon carrying case



TIF 9055

Programmable Charging / Recovery Meter up to 100 kg



TIF 9055

Features

- 100 kg (220 lbs) capacity
- Allows automatic Charging or Recovery operations
- Color-coded keypad controls
- Three display modes – Kilograms, lbs/oz, Decimal Pounds
- Very High Resolution – 4 g / 0.2 oz / 0.010 lbs
- Can be used with all refrigerants, including High Pressure (R410A)
- Advanced Charge and Recovery Modes – uses tare weight & Max. capacity of cylinder to calculate maximum Charge/Recovery available
- User Programmable memory for up to 99 different stored values
- “Repeat” charge feature
- Removable platform and control box with prop stand/hanging hook
- Compact Design – completely portable, battery powered
- Low battery indicators
- CE approved
- One year warranty

Specifications

Range	0 kg to 100 kg or 0 lbs to 219 lbs or 0 lbs 0.0 oz to 219 lbs 0.0 oz
Resolution	4 gram / 0.2 oz / 0.010 lbs
Accuracy	±0.5 % of reading, ±1 digit
Power Supply	4 x 1.5 V batteries and one 9 V alkaline battery
Battery Life	30 hours
Max. Solenoid operating pressure	34.4 bar (500 psi)
Operating Temperature	-10 °C to 45 °C
Inlet/Outlet Ports	1/4" MFL fittings with 1/2" ACME adapters



ROBINAIR VACUUM PUMPS

The Importance of Deep Vacuum



RA 15401

The purpose of a vacuum pump is to remove moisture and air from an A/C-R system. Modern systems are built tighter and charges are more critical. That means these systems have a greater sensitivity to moisture and other contaminants, making thorough evacuation more important than ever before.

Moisture in a refrigeration system, directly or indirectly, is the cause of most problems and complaints. First, moisture can cause a freeze-up in a system. Moisture is picked up by the refrigerant and transported through the refrigerant line in a fine mist, with ice crystals forming at the point of expansion.

A "freeze-up" is not the only problem caused by moisture. It can also result in corrosion, the effects of which are not apparent until the real damage has occurred. Moisture alone is bad enough, but combined with refrigerants containing chlorine, hydrochloric acids can form. These greatly increase the corrosion of metals.

Also, refrigerant oil rapidly absorbs moisture. Water-formed acids combine with the refrigerant, forming a closely bonded mixture of fine globules. The effect is called sludging and it greatly reduces the lubricating ability of the oil. A vacuum pump removes troublesome moisture by lowering the pressure within the system and vaporizing (or boiling off) the moisture, then exhausting it along with air.

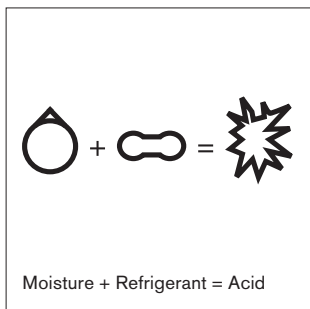
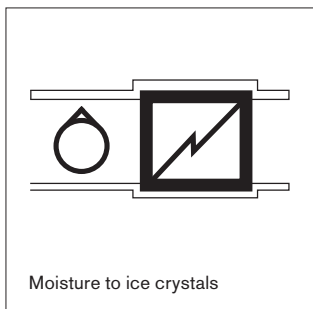

Oil Fill Port –
Makes adding oil simple since the port is accessible from the front or either side. The sight glass on the front of the pump shows you when enough oil has been added.

Heavy-Duty Motor –
High torque design for easy startup and efficient operation.

Offset Rotary Vanes –
Our proven design builds a powerful compression within the pumping chamber to reduce system pressure and vaporize moisture so it can be exhausted along with air.

Molded Base –
Durable polycarbonate base improves pump balance and minimizes vibration during operation.

Gas Ballast – Moisture laden air passing through the pump mixes with relatively dry air to such a degree that compression does not cause condensation.

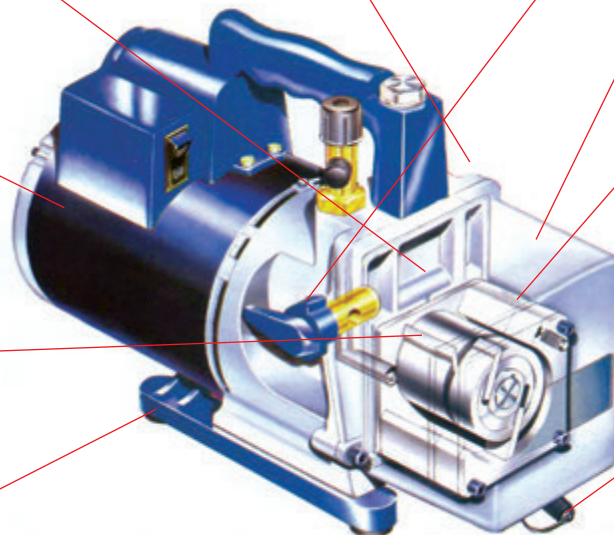

Iso-Valve™ –
Isolates the pump from the system with just a quarter-turn.

Die-Cast Aluminium Housing –
Cast aluminium housings make the pumps lightweight but durable.

Two Stage Design –
Cleans the system more thoroughly than a single-stage pump; the second stage starts pumping at a lower pressure so you can pull a deeper, ultimate vacuum.

Oil Drain Valve –
Positioned at the bottom of the oil reservoir and angled for faster, more complete draining.



RA 15401 · RA 15601 RA 15121A

Cooltech™ Vacuum Pumps

COOLTECH

ROBINAIR®



RA 15401 - 4 CFM

Suitable for 230 V and 115 V, with IEC connector and EU 230 V power cord.

Specifications RA 15401 - 4 CFM

Capacity	93 l/min
No. of Stages	2
Ultimate Vacuum	20 Microns
Intake Fittings	1/4" MFL + 1/2" MFLT + 3/8 MFL
Oil Capacity	445 ml (15 oz)
Motor Size	244 W (1/3 HP)
Power Supply	115 V, 60 Hz / 230 V, 50 Hz
Weight	12 kg (27 lbs)
Dimensions	24,7 x 14,25 x 42 cm (9,5" x 5,5" x 16,5")



RA 15601 - 6 CFM

Specifications RA 15601 - 6 CFM

Capacity	142 l/min
No. of Stages	2
Ultimate Vacuum	20 Microns
Intake Fittings	1/4" MFL + 1/2" MFLT + 3/8 MFL
Oil Capacity	445 ml (15 oz)
Motor Size	366 W (1/2 HP)
Power Supply	115 V, 60 Hz / 230 V, 50 Hz
Weight	12 kg (27 lbs)
Dimensions	24,7 x 14,25 x 42 cm (9,5" x 5,5" x 16,5")



RA 15121A - 10 CFM

Specifications RA 15121A - 10 CFM

Capacity	236 l/min
No. of Stages	2
Ultimate Vacuum	20 Microns
Intake Fittings	1/4" MFL + 1/2" MFLT + 3/8 MFL
Oil Capacity	488 ml (16,5 oz)
Motor Size	366 W (1/2 HP)
Power Supply	115 V, 60 Hz / 230 V, 50 Hz
Weight	17 kg (38,6 lbs)
Dimensions	27,2 x 14,3 x 44,5 cm (10,7" x 5,6" x 17,5")



RA 15301-E · RA 15501-E

VacuMaster™ Vacuum Pumps



RA 15301-E



RA 15501-E

Features

- Lighter and Quieter
- Handle makes transport easier
- Standard IEC connector for power cord makes using different length and configuration power cords easy (1.8 m length with standard European plug included)
- Utilizes Robinair's proven offset rotary vane design
- Two Stage permits deep vacuum to be reached in all conditions
- Includes Large analog Vacuum Gauge for easy measurements and leak checking
- Solenoid valve ensures vacuum is held in system in the event of power loss
- Combined Oil Fill/Exhaust plug
- Convenient Oil Drain plug for quick oil changes
- Standard 1/4" MFL connector with 3/8" MFL adapter
- Solid Metal base for strength and durability
- Field serviceable
- Supplied with one bottle of Robinair Premium High Vacuum Pump Oil

Specifications RA 15301-E – 75 l/min

Free Air Displacement (Capacity)	75 Liters/Minute
Ultimate Vacuum	30 Microns
Power Supply	220 - 240 V / 50 Hz / 1.3 A
Oil Capacity	350 ml
Weight	9.5 kg
Dimensions	320 x 140 x 255 mm

Specifications RA 15501-E – 125 l/min

Free Air Displacement (Capacity)	125 Liters/Minute
Ultimate Vacuum	30 Microns
Power Supply	220 - 240 V / 50 Hz / 1.5 A
Oil Capacity	450 ml
Weight	11.5 kg
Dimensions	340 x 150 x 270 mm



RA 13119 · RA 13203 · RA 13204

ROBINAIR Premium High Vacuum Pump Oil



RA 13119 · RA 13203 · RA 13204

Features

- Mineral oil
- Chemically engineered to maintain maximum viscosity at high running temperatures and to improve cold weather starts
- Thermal stability – resists break-down due to heat
- Lower moisture content – due to special packaging and handling procedures
- Performance of your pump depends largely on the quality and purity of the vacuum pump oil that you use

RA 13119	Premium High Vacuum Pump Oil, Pint Bottle 0.475 l (16 oz) (case of 12 bottles)
RA 13203	Premium High Vacuum Pump Oil, Quart Bottle 0.95 l (32 oz) (case of 12 bottles)
RA 13204	Premium High Vacuum Pump Oil, Gallon Bottle 3.8 l (128.5 oz) (case of 4 bottles)

RA 13047A

ROBINAIR Vacuum valve assembly



RA 13047A

Valve assemblies give the service technician maximum control during evacuation and recharging. Installed directly to the vacuum pump, they connect the pump, manifold and thermistor gauge, providing one central control. Saves time – no need to connect/disconnect hoses. Made of durable forged brass for long life.

RA 13047A	1/2" FFL Coupler x 1/4" MFL x 3/8" MFL, Large internal porting for high CFM flow
-----------	--

PROMAX®



ROBINAIR®

R32



CO₂

R290/
600a

ADDITIONAL INFORMATION THROUGH YOUR SMARTPHONE OR TABLET

This catalogue contains additional information. With your smartphone or tablet you can download it through this page.

Simply more to enjoy:

1. Install the Junaio App for free.
 2. Scan with the app the QR-Code
 3. Hold your smartphone or tablet over this page.
- That's it.



RA VG-1

Digital Micron Gauge



RA VG-1

Unique, first in industry, tri-color backlight provides at-a-glance indication of vacuum status

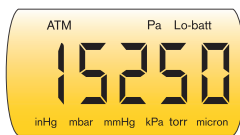

Standard Display mode with YELLOW backlight, showing decreasing vacuum measurement.

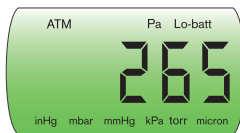

Once the pressure has been drawn below 275 Microns, the backlight turns GREEN – indicating an acceptable vacuum level is reached.

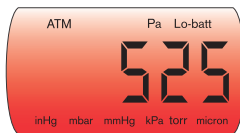

If the pressure fails to reach 500 Microns after an extended period, or rises back above 500 Microns after reaching the “green zone”, the backlight turns RED.



Includes Tee fittings for connection to system – 1/4" MFL x 1/4" MFL and 1/4" FFL x 1/4" MFL, allowing for either in-line hook-up or directly onto a manifold.

Robinair proudly introduces one of the most sophisticated Digital Micron (vacuum) Gauges available for field service. Packaged in the same convenient case as our successful Digital Pressure gauges, this stand alone gauge is compact and can be used anywhere.

The RA VG-1 employs a sophisticated MEMS Pirani type sensor that directly measures flow. Unlike all other field service gauges on the market, the RA VG-1 is NOT affected by temperature. The RA VG-1 measures vacuum from Atmosphere to 10 microns in 6 different scales, and can withstand overpressure beyond 30 bar. The unit employs an industry first multi-color backlight that functions as an instant go/no go indicator of acceptable vacuum or leakage.

Features

- Patent Pending design, employs a sophisticated MEMS Pirani sensor
- Range from Atmosphere down to 10 microns
- Measure vacuum in Microns, mmHg, inHg, mBar, Pascals or Torr
- Extremely accurate at low micron levels
- High Resolution and unique backlight indicator make precision readings easy
- Impact and water resistant case with protective Rubber boot
- Rapid response to changes in vacuum
- Large easy to read 5 digit display
- Auto shut off feature prolongs battery life
- Battery powered
- Integrated “magnetic” hook
- Includes carrying case and tee adapters for in-line connections (1/4" MFL x 1/4" MFL and 1/4" FFL x 1/4" MFL versions)

Specifications

Operating Range	Atmosphere to 10 Microns
Resolution	As low as 5 Microns / 0.005 mmHg / 0.002 inHg / 0.007 mBar / 0.66 Pa / 0.005 Torr
Accuracy	As low as ±5 % of RDG
Overpressure	~ 31 Bar/450 psi
Measuring Units	Microns / mmHg / inHg / mBar / Pa / Torr
Display	5 digit STN LCD, 50 x 30 mm with tri-color LED backlight
Power Supply	3 x size “AAA” 1.5 V Batteries
Input Connection	1/8"-27 NPT Male

RA VG-64

Digital Vacuum Gauge



A durable self-contained battery powered vacuum gauge with LCD readout. Allows reading from 12000 to 0 microns. The unique design of the RA VG-64 allows in-line connection through the system or directly at the vacuum pump.

Features

- Easy to use
- LCD readout allows easy readings
- Sensor type: Thermistor
- 1/4" connections
- Power supply: 9 V Battery
- Rugged plastic case
- Convenient built-in hanger
- Connections provides quick cleaning and drying of sensor

Specifications

Dimension	135 x 75 x 40 mm
Connections	1/4" MFL
Power Supply	9 V Battery
Sensor Type	Thermistor
Response Time	0,5 sec
Units	Micron, psi, InHg, Millibar, Pascal, Torr, Millitor
Battery Life	Approx. 30 hours
Automatic Shutt Off	After 10 minutes of vacuum readings are above 12000 microns
Resolution	0-200: 1 micron 201-500: 5 micron 501-1000: 10 micron 1001-2000: 50 micron 2001-5000: 250 micron 5001-8000: 500 micron 8001-12000: 1000 micron
Accuracy	±10 % of reading
Maximum Pressure	20 bar/300 psi
Operating Temperature	2 °C to 52 °C



RA 14777

Compact Electronic Thermistor Vacuum Gauge



RA 14777

Features

- Compact, pocket-size – 64 x 76 mm (2.5" x 3")
- Takes guess work out of evacuation – accurately indicates when system is ready for recharge
- Designed for use under high vacuum, reads down to 10 microns
- Easy-to-read LCD, automatically registers smaller numeric segments as system pulls down
- 6' long lead and magnetic mounting strip – allows for convenient, easy to read, positioning

Specifications

Range	25,000 to 10 microns
Vacuum Fitting	1/4" FFL
Power Supply	9 V battery (included)

RA 14010A

Thermistor Vacuum Gauge



RA 14010A

Proven design Analog Thermistor permits measurements using both direct and null method.

Features

- Large analog meter – clearly marked for easy reading of micron levels
- Indicates actual vacuum level in the system
- Measures from 25,000 to 0 microns
- Two operation modes – select between the null method for greatest accuracy or direct meter reading for continuous monitoring of the evacuation process
- Proven bridge circuit compensates for changes in ambient temperature from -1° to 49° C (30° to 120° F) and also for variances in battery voltage
- Rugged carrying case, protects unit during transit and use

Specifications

Range	25,000 to 0 microns
Vacuum Fitting	1/4" FFL
Power Supply	6 x 1,5 V "C" cell batteries

Replacement Parts

Replacement Thermistor Tube	RA 17162
-----------------------------	----------

Optional Accessories

Optional A/C Power Adapter	RA 17160 (115 V/60 Hz)
----------------------------	------------------------

MANIFOLDS

Manifold Sets



ROBINAIR is proud to introduce an **ALL NEW** complete line of Refrigerant service Manifolds.

Features

- 2-Way and 4-Way manifolds
- Aluminium block
- Piston valves for full flow
- Digital gauges include 24 refrigerants
- Analog gauges are 80 mm Class 1.0
- Available separate or as Set with hoses and carrying case



RA 41178-E



RA 42282-E



RA 43160-E



RA 40025E



Piston-type seat ensures positive shut-off with minimal force.

Double o-ring seal ensures leak free operation.

NEW

- Now also available R32/410A, R290/600/600a (Class 1.6)
- And also for CO₂

R32, R290/600a, CO₂



MANIFOLDS



Manifold Set Selection Chart

Refrigerants for Digital Gauge Sets	Manifold Block	Case	Hose set	Model Number
R12, R22, R123, R124, R134a, R401A, R401B, R402A, R402B, R404A, R407C, R409A, R410A, R417A, R422A, R422D, R427A, R502, R507, R1234yf, R32, R290, R600, R600a	2-Way	No	None	RA 43180E
		Yes	90 cm	RA 43180E90C
			150 cm	RA 43180E150C
	4-Way	No	None	RA 43160E
		Yes	90 cm	RA 43160E90C
			150 cm	RA 43160E150C

Refrigerants for Analog Gauge Sets	Manifold Block	Case	Hose set	Model Number
R22, R407C, R410A Especially for Air Conditioning	2-Way	No	None	RA 41138E
		Yes	90 cm	RA 41138E90C*
			150 cm	RA 41138E150C*
	4-Way	No	None	RA 42238E
		Yes	90 cm	RA 42238E90C*
			150 cm	RA 42238E150C*

Only R410A	2-Way	No	None	RA 41148E
		Yes	150 cm	RA 41148E150C
	4-Way	No	None	RA 42248E
		Yes	150 cm	RA 42248E150C

R422D, R404A, R407C, R134a	2-Way	No	None	RA 41182E
		Yes	90 cm	RA 41182E90C
			150 cm	RA 41182E150C
	4-Way	No	None	RA 42282E
		Yes	90 cm	RA 42282E90C
			150 cm	RA 42282E150C

R22, R404A, R407C, R134a	2-Way	No	None	RA 41178E
		Yes	90 cm	RA 41178E90C
			150 cm	RA 41178E150C
	4-Way	No	None	RA 42278E
		Yes	90 cm	RA 42278E90C
			150 cm	RA 42278E150C

R290, R600, R600a NEW	2-Way	No	None	RA 41190E
	4-Way			RA 42290E

R32, R410A NEW Especially for Air Conditioning	2-Way	No	None	RA 41132E
		Yes	90 cm	RA 41132E90C*
			150 cm	RA 41132E150C*
	4-Way	No	None	RA 42232E
		Yes	90 cm	RA 42232E90C*
			150 cm	RA 42232E150C*

*includes RA RG 0,90-5-4
5/16" Female x 1/4" Male SAE, 90°

MANIFOLDS

Manifold Set R-744 (CO₂)



Features

- 2-Way Manifold
- Available separate or as Set with hoses and carrying case
- Analog gauges ø 80 mm, oil filled, metal casing
- High pressure gauge 1 to 160 bar
- Low pressure gauge -1 to 100 bar
- Hose lenght 3 m
- Hose connection 1/4" SAE (7/16" UNF)
- PTFE hoses with stainless steel braid
- Working pressure 224 bar (-70 to 230 °C)
- Burst pressure 672 bar

2-Way Manifold for R-744 (CO ₂)	RA 411744-E
Hose Set for R-744 (CO ₂) 3 m (3 pieces)	RA 744300
Set containing RA 411744-E and RA 744300 in carrying case	RA 411744E300C



Replacement Parts

Replacement gauge LP	RA 411744LP
Replacement gauge HP	RA 411744HP



See also our additional products for CO₂

NEW CO₂



Page 8



Page 49



Page 49



RA 11910-E

Digital Gauge



RA 11910-E (Low Pressure)

Specifications RA 11910-E (Low Pressure)

Operating Range	0 to 55.15 bar / 0 to 800 psi / 0 to 56.25 kg/cm ² / 0 to 5.515 MPa
Accuracy	±1 % full pressure for 0 to 34.47 bar (0-500 psi) range ±2.5 % full pressure for 34.47 bar to 55.15 bar (500-800 psi) range
Resolution	0.05 bar / 0.5 Psi / 0.05 kg/cm ² / 0.005 MPa / 0.1 inHg / 0.5 mmHg Temperature: 1 °C / 1 °F
Overpressure	150 % of the range overpressure is 87.72 bar
Burst Pressure	5 times nominal pressure range
Measurement Units	Bar / PSI / kg/cm ² / MPa Vacuum is in Hg / mmHg / MPa Temperature: °C / °F
Display	Display type: Positive LCD with BLUE backlight LCD size: 50 x 30 mm
Power Supply	3 x 1.5 V AAA alkaline batteries replaceable Battery Life: Approximately 140 hours
Input Connection	1/8" - 27 NPT Male Fitting

Features

- Displays pressure and temperature charts for 24 refrigerants: R12, R22, R123, R124, R134a, R401A, R401B, R402A, R402B, R404A, R407C, R409A, R410A, R417A, R422A, R422D, R427A, R502, R507, R1234yf, R32, R290, R600 and R600a
- Backlit LCD, for easy reading in all conditions
- Simple two button operation
- Self powered by "AAA" batteries
- Low Side gauge displays vacuum
- 4 user selectable pressure scales – Bar, PSI, kg/cm² and MPa
- Temperature can be displayed in degrees Celsius or Fahrenheit
- Auto Shut Off Feature
- High Accuracy
- Overpressure protected to 150 % of range; pressure overload indication
- Multi panel displays; 4 digit LCD for pressure, 3 digits for temperature
- Units supplied with standard 1/8" NPT fitting for mounting to any manifold or panel application
- Low Battery Indication
- Tare function to zero the gauge at any pressure
- High Impact ABS housing and protective rubber boot



RA 11920-E

Digital Gauge



RA 11920-E (High Pressure)

Features

- Displays pressure and temperature charts for 24 refrigerants: R12, R22, R123, R124, R134a, R401A, R401B, R402A, R402B, R404A, R407C, R409A, R410A, R417A, R422A, R422D, R427A, R502, R507, R1234yf, R32, R290, R600 and R600a
- Backlit LCD, for easy reading in all conditions
- Simple two button operation
- Self powered by "AAA" batteries
- 4 user selectable pressure scales – Bar, PSI, kg/cm² and MPa
- Temperature can be displayed in degrees Celsius or Fahrenheit
- Auto Shut Off Feature
- High Accuracy
- Overpressure protected to 150 % of range; pressure overload indication
- Multi panel displays; 4 digit LCD for pressure, 3 digits for temperature
- Units supplied with standard 1/8" NPT fitting for mounting to any manifold or panel application
- Low Battery Indication
- Tare function to zero the gauge at any pressure
- High Impact ABS housing and protective rubber boot

Specifications RA 11920-E (High Pressure)

Operating Range	0 to 55.15 bar / 0 to 800 psi / 0 to 56.25 kg/cm ² / 0 to 5.515 MPa
Accuracy	±1 % full pressure for 0 to 34.47 bar (0-500 psi) range ±2.5 % full pressure for 34.47 bar to 55.15 bar (500-800 psi) range
Resolution	0.05 bar / 0.5 Psi / 0.05 kg/cm ² / 0.005 MPa / 0.1 inHg / 0.5 mmHg Temperature: 1 °C / 1 °F
Overpressure	150 % of the range overpressure is 87.72 bar
Burst Pressure	5 times nominal pressure range
Measurement Units	Bar / PSI / kg/cm ² / MPa Vacuum is in Hg / mmHg / MPa Temperature: °C / °F
Display	Display type: Positive LCD with BLUE backlight LCD size: 50 x 30 mm
Power Supply	3 x 1.5 V AAA alkaline batteries replaceable Battery Life: Approximately 140 hours
Input Connection	1/8" - 27 NPT Male Fitting



ANALOG GAUGES

For Manifold Sets

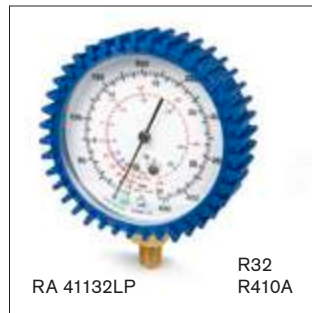
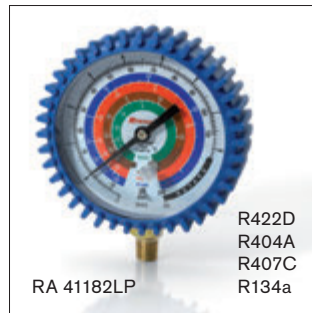
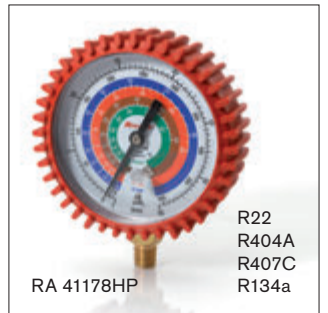
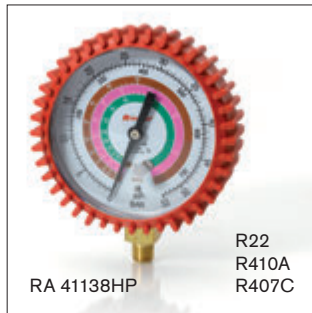
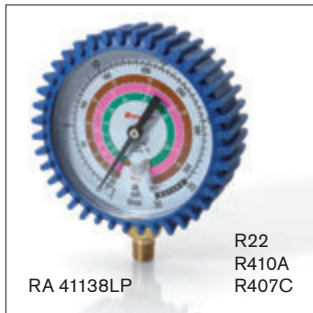

Analog Gauges Selection Chart

Refrigerants	Low Pressure (Blue)	High Pressure (Red)
R22, R410A, R407C For Air Conditioning	RA 41138LP	RA 41138HP
Only R410A	RA 41148LP	RA 41148HP
R422D, R404A, R407C, R134a	RA 41182LP	RA 41182HP
R22, R404A, R407C, R134a	RA 41178LP	RA 41178HP
R290, R600, R600a	RA 41190LP	RA 41190HP
R32, R410A For Air Conditioning	RA 41132LP	RA 41132HP

REPLACEMENT PARTS FOR MANIFOLDS

For Manifold Sets



Manifold Block

RA 41140E	2-Way Manifold Block
RA 42240E	4-Way Manifold Block

Adapter

RA 894A	Adapter 3/8" FFL x 1/4" MFL
---------	-----------------------------

Repair Kits

RA 41140P	Piston repair kit 2-Way Block
RA 42240P	Piston repair kit 4-Way Block
RA 41140SPK	Complete repair kit 2-Way Block
RA 42240SPK	Complete repair kit 4-Way Block

Replacement Knobs

RA 42240KBK	Replacement Knob Black
RA 42240KYW	Replacement Knob Yellow
RA 42240KBE	Replacement Knob Blue
RA 42240KRD	Replacement Knob Red

Optional Accessories

Rubber Boot Red	RA 40020HP
Rubber Boot Blue	RA 40010LP
Carrying case Red	RA 40025E



ROBINAIR ENVIRO-GUARD™

Refrigerant Charging Hoses



Features

- **Quick Seal™ Fittings** – Automatically seal and prevent refrigerant from discharging when hoses are disconnected
- **Enviro-Guard™ Hoses** – Special barrier material prevents permeation of refrigerant
- High working and burst pressure make these hoses ideal for ALL refrigerants
- All hoses are equipped with a 45° bend fitting on one end, for convenient access to the system

Robinair Hose Selection Chart

1/4" FFL Enviro-Guard™ High Pressure (R410A) Hoses with **Quick Seal™** fittings
51 bar (740 psi) working pressure/255 bar (3700 psi) burst pressure

Length	Yellow	Blue	Red	Set (Yellow, Blue, Red)
90 cm / 36"	RA 68136A	RA 68236A	RA 68336A	RA 69036A
150 cm / 60"	RA 68160A	RA 68260A	RA 68360A	RA 69060A
180 cm / 72"	RA 68172A	RA 68272A	RA 68372A	RA 69072A
240 cm / 96"	RA 68196A	RA 68296A	RA 68396A	RA 69096A

1/4" FFL x 5/16" FFL 45° **Quick Seal™** fittings; 55 bar (800 psi) working pressure/275 bar (4000 psi) burst pressure

Length	Set (Yellow, Blue, Red)
150 cm / 60"	RA 410860A

1/4" FFL x 5/16" FFL 45° standard fittings; 55 bar (800 psi) working pressure/275 bar (4000 psi) burst pressure

Length	Set (Yellow, Blue, Red)
150 cm / 60"	RA 410Q60S

5/16" FFL x 5/16" FFL 45° standard fittings; 51 bar (740 psi) working pressure/255 bar (3700 psi) burst pressure

Length	Set (Yellow, Blue, Red)
150 cm / 60"	RA 410A60S

1/4" FFL x 1/4" FFL 45° standard fittings; 55 bar (800 psi) working pressure/275 bar (4000 psi) burst pressure

Length	Set (Yellow, Blue, Red)
150 cm / 60"	RA 70060A

1/4" FFL Standard Hoses with standard fittings 34.4 bar (500 psi) working pressure/172 bar (2500 psi) burst pressure

Length	Yellow	Blue	Red	Set (Yellow, Blue, Red)
90 cm / 36"	RA 31036	RA 32036	RA 33036	RA 30036
150 cm / 60"	RA 31060	RA 32060	RA 33060	RA 30060
180 cm / 72"	RA 31078	RA 32072	RA 31079	RA 30072
240 cm / 96"	RA 31096	RA 32096	RA 33096	not available

SPECIAL HOSES

ROBINAIR Special Hoses for Special Jobs



14 MM X 1/2" ACME

Automotive Hose for R134a

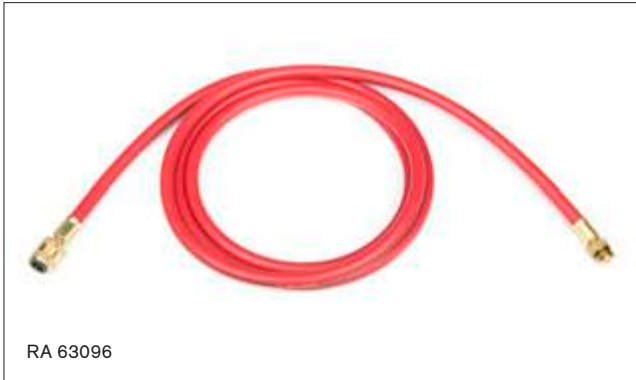

RA 63096

RA 63096	51 bar (740 psi) working pressure, 255 bar (3700 psi) burst pressure Red – 240 cm / 96"
RA 62121	51 bar (740 psi) working pressure, 255 bar (3700 psi) burst pressure Blue – 240 cm / 96"



RA 62121

Length 240 cm



RA 68060

3/8" FFL

Charging and Vacuum Hoses

These larger diameter hoses reduce pull-down time by as much as 40 %.

RA 68060	150 cm (60") Enviro-Guard™ Hose, 3/8" FFL, with standard straight fittings
----------	--



ROBINAIR REPLACEMENT PARTS



For Hoses, Adapters and Couplers

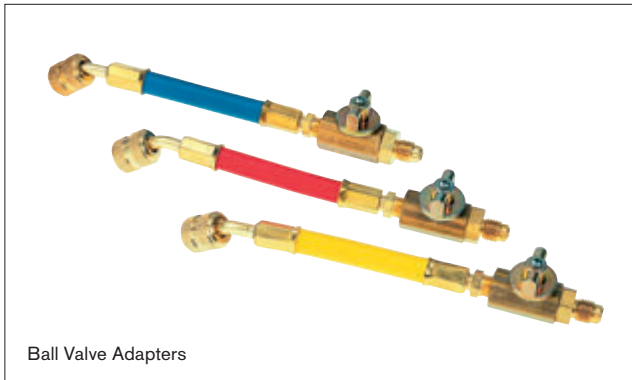

Ball Valve Adapters

Ball Valve Adapters

These 15 cm (6") adapters connect to any 1/4" FFL charging hose for convenient in-line control of refrigerant flow. The ball valve opens and closes in just a quarter turn. The fitting features a 45° bend for easier connections, even in tight spots.

RA 18501	1/4" MFL x 1/4" FFL, Blue
RA 18512	1/4" MFL x 1/4" FFL, Red
RA 18513	1/4" MFL x 1/4" FFL, Yellow
RA 18514	1/4" MFL x 1/4" FFL, Blue, Red and Yellow (Set of 3)
RA 18511	1/4" MFL x 3/16" FFL, Red

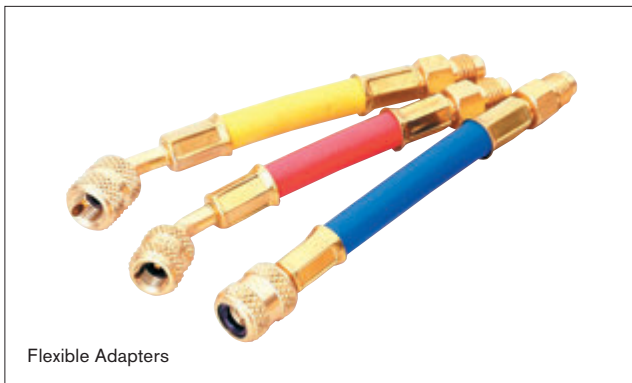

Flexible Adapters

Flexible Adapter

Flexible adapters feature brass fittings and durable neoprene coated hose, 6"

RA 10778	1/4" MFL x 1/4" FFL, Yellow
----------	-----------------------------



RA 18180

RA 40083

ROBINAIR Replacement Parts for Hoses, Adapters and Couplers

RA 40082	1/4" Valve Core Depressors for Hoses & Adapters (Set of 6)
RA 40083	1/4" Gaskets for Hoses & Adapters (Set of 6)
RA 40084	3/8" Gaskets for Hoses & Adapters (Set of 6)

QUICK SEAL™ Repair Kits (for Hoses and Adapters)

RA 18180	1/4" Quick Seal O-Ring Set (Set of 6)
RA 18451	45°, 1/4" Quick Seal Repair Kit



RA 40563A

90° Style Adapters

Solid brass fitting is ideal for tight spots

RA 40563A	1/4" MFL x 1/4" FFL
-----------	---------------------

ACCESSORIES AND REPLACEMENT PARTS

ROBINAIR®

For Adapters and Couplers



RA 1000HS · RA 1000FS

RA 1000FS · RA 1000HS Refrigerant Saver Couplings with valve core Depressors

This family of service fittings provides a convenient, safe and reliable way of connecting to refrigeration or air conditioning systems without releasing refrigerant to the environment. Each valve attaches to the system without depressing the valve core. Once installed, opening the knob depresses the valve core on the system and simultaneously opens the valve inside.

Features

- Solid Brass construction
- Two sizes of straight valve
- Ultra-compact right angle valve for tight spaces
- Fitting does not depress Schrader™ during installation - easier to install, no refrigerant loss
- Seals compatible with all refrigerants and oils
- Diamond knurl for easy grip
- Available in either 1/4" or 5/16" Flare sizes

Specifications straight Valves

RA 1000FS	1/4" MFL x 1/4" FFL	58 mm High
RA 1000HS	5/16" MFL x 5/16" FFL	58 mm High

Repair Kit

RA 1000 Gasket	Replacement Seal
----------------	------------------

1/4" SAE = 7/16" UNF

5/16" SAE = 1/2" UNF



BALL VALVES

ROBINAIR RA BV Series Ball Valves 1/4-turn

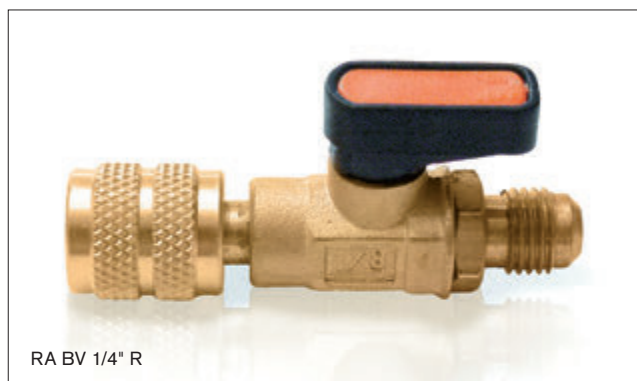

RA BV 1/4" R

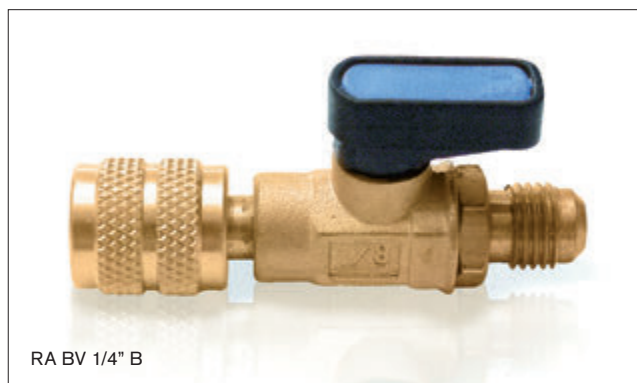

RA BV 1/4" B

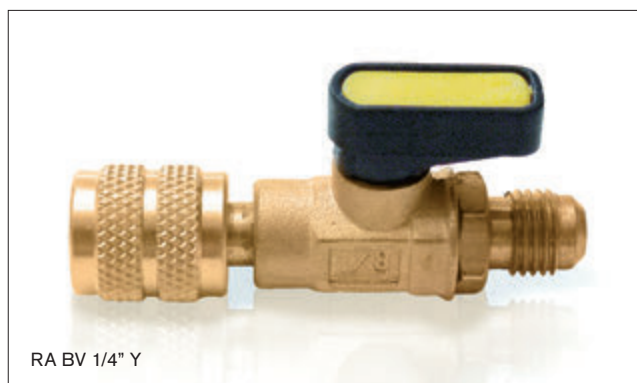

RA BV 1/4" Y

Features

- Solid Brass Construction
- Connect between a service hose and refrigerant source to contain refrigerant in hose before disconnecting
- Allows manual shut-off of hose at any point during use
- Positive shut-off 1/4-turn ball valve
- Color coded handles, Red, Blue and Yellow
- Available in 1/4" x 1/4", 1/4" x 5/16" and 5/16" x 5/16" Flare combinations
- Only 60 mm long

Valve Selector Chart

Fitting Size	RED Handle
1/4" FFL x 1/4" MFL	RA BV 1/4" R
5/16" FFL x 1/4" MFL	RA BV 1/4" x 5/16" R
5/16" FFL x 5/16" MFL	RA BV 5/16" x 5/16" R

Fitting Size	BLUE Handle
1/4" FFL x 1/4" MFL	RA BV 1/4" B
5/16" FFL x 1/4" MFL	RA BV 1/4" x 5/16" B
5/16" FFL x 5/16" MFL	RA BV 5/16" x 5/16" B

Fitting Size	YELLOW Handle
1/4" FFL x 1/4" MFL	RA BV 1/4" Y
5/16" FFL x 1/4" MFL	RA BV 1/4" x 5/16" Y
5/16" FFL x 5/16" MFL	RA BV 5/16" x 5/16" Y

1/4" SAE = 7/16" UNF

5/16" SAE = 1/2" UNF

ACCESSORIES AND REPLACEMENT PARTS

For Adapters and Couplers

ROBINAIR®

QUICK SEAL™ ADAPTERS

Quick Seal™ fitting automatically shuts off the charging hose when you disconnect it from the system, so any refrigerant left in the hose is not released. This also prevents "finger burn" and adds an extra measure of safety. Made of solid brass.

RA 10292	1/4" MFL x 1/4" FFL
RA 10250	1/4" MFL x 1/4" FFL, 90° Elbow



RA 10292 · Quick Seal™

RA RG180-5-4 RA RG0,90-5-4 ROBINAIR Couplers

RA RG180-5-4	5/16" Female x 1/4" Male SAE
RA RG0,90-5-4	5/16" Female x 1/4" Male SAE, 90°



RA RG180-5-4 · RA RG0,90-5-4

R410A



QUICK COUPLERS

ROBINAIR®

RA 18190A · RA 18191A

ROBINAIR

Service Couplings for Automotive

Features

- Compact Design
- For Automotive R134a or R1234yf
- Six Ball Coupler to provide a more stable grip on the fitting
- Female connection 14 mm or 1/4" SAE male (for R134a)



RA 19885 · RA 19886

RA 18190A	Coupler LP for R134a, female connection 14 mm
RA 18191A	Coupler HP for R134a, female connection 14 mm
RA 19885	Coupler LP for R134a, male connection 1/4" SAE
RA 19886	Coupler HP for R134a, male connection 1/4" SAE
RA LPHFO1234yf	Coupler LP for R1234yf, female connection 12 mm
RA HPHFO1234yf	Coupler HP for R1234yf, female connection 12 mm
RA HFO1234yf	Adapter 12 mm x 1/4" SAE male connection

Repair Kit

RA 19150	Set replacement seals for RA 18190A and RA 18191A
----------	---



RA LPHFO1234yf · RA HPHFO1234yf



RA HFO1234yf

QUICK COUPLERS



16-C



17-C

16-C / 17-C / 18-C / 26-C / 27-C Kwik-Coupler® – Service Hose Shut-Off

The Kwik-Coupler® set is intended for use with refrigeration and air-conditioning service hoses when connecting to core valve type access fittings. Conventional threaded connecting is converted to push/pull operation which is faster, easier and positive sealing at all times. Valve cores are depressed automatically without adjustments or loss of refrigerant. Disconnecting is also accomplished without loss of refrigerant. An automatic shut-off valve retains refrigerant pressure in a disconnected hose. This feature permits transferring high side hose refrigerant through the service manifold into the low side, thereby eliminating waste and hazardous high pressure discharge and atmospheric damage.

Features

- Also available in 5/16" SAE for R410A
- Automatic full depression of core valves without adjustment, regardless of core position
- Coupler halves separately connect to access fitting and hose end, then easy push/pull operation automatically opens or closes system without loss of refrigerant
- Automatic shut-off of hose ends permits discharging high side hose through manifold into low side
- Eliminates hazardous discharge of refrigerant and oil from system when disconnecting hose
- Simplifies operation of charging critical amount of refrigerant into small systems
- Prevents finger burn when disconnecting - especially servicing heat pumps in cold weather
- Core depressors in hose ends no longer necessary - speeds servicing of systems with hand valves

Replacement Seals

S8920073	Replacement Seal for 16-C, 17-C, 18-C (10 pieces)
S10000996	Replacement Seal for 26-C, 27-C (10 pieces)

16-C	Straight Coupler (45° Flare) 1/4" female x 1/4" male
17-C	90° Elbow Coupler (45° Flare) 1/4" female x 1/4" male
18-C	(Set) includes 16-C and 17-C
26-C	Straight Coupler (45° Flare) 5/16" female x 5/16" male
27-C	90° Elbow Coupler (45° Flare) 5/16" female x 5/16" male

(26-C and 27-C Not UL Approved)



23-C and 24-C

23-C / 24-C Shut-Off Couplers

Coupler captures refrigerant within the hose when disconnecting.

23-C	Straight, 1/4" SAE
24-C	90°, 1/4" SAE



RA 825GN-50

Nitrogen Pressure Regulator 50 bar



Features

- Solid and stable Nitrogen pressure regulator
- Easy single valve system
- Max pressure overload protection of 50 bar
- Overpressure protection
- 1/4" SAE standard connection
- Inlet pressure up to 230 bar
- Standard nitrogen bottle connection (W24, 32 x 1/14")

RA 825GN-55

Nitrogen Pressure Regulator 55 bar



Features

- Solid and stable Nitrogen pressure regulator
- Easy single valve system
- Max pressure overload protection of 55 bar
- Overpressure protection
- 1/4" SAE standard connection
- Inlet pressure up to 230 bar
- Standard nitrogen bottle connection (W24, 32 x 1/14")

RA 987GN-170

Nitrogen Pressure Regulator 170 bar

ROBINAIR®



Features

- Solid and stable Nitrogen pressure regulator
- Rubber boots protect gauges during use and storage
- Easy single valve system
- Safely regulate outlet pressure up to 170 bar
- Overpressure protection
- Inlet Pressure up to 300 bar
- 1/4" SAE standard connection
- Standard nitrogen bottle connection (W24.32 x 1/14")

RA 987Z117ATP

CO₂ Pressure Regulator 100 bar



Features

- Solid and stable CO₂ pressure regulator
- For vapor and liquid CO₂
- Rubber boots protect gauges during use and storage
- Easy single valve system
- Max pressure overload protection of 100 bar
- Overpressure protection
- Inlet pressure up to 300 bar
- 1/4" SAE standard connection
- Standard CO₂ bottle connection (W21,8 x 1/14" RH)



RA 825H2-50

Hydrogen Pressure Regulator 50 bar



Features

- Solid and stable hydrogen pressure regulator
- Easy single valve system
- Max pressure overload protection to 50 bar
- Overpressure protection
- G 3/8 LH Hose connection
- Inlet pressure up to 230 bar
- Standard hydrogen bottle connection (W21,80 x 1/14")

REPLACEMENT PARTS FOR PRESSURE REGULATORS

RA 6639-MO	Replacement Seal
RA H100	Replacement pressure gauge 0 - 100 bar
RA 615N	Replacement pressure gauge 0 - 315 bar
RA 621N	Replacement pressure gauge 0 - 400 bar

GALAXY

Electronic Condensate Pump



95 %

It is impossible for one condensate pump to fit all applications BUT our GALAXY electronic condensate pump fits in 95% of all circumstances.

The easily integrated filter provides optimum protection for the dirtiest environments.

The new GALAXY Electronic Condensate Pump has been designed to meet the more demanding challenges of modern installations. The compact electronic sensor can be mounted in most positions, making it the most versatile sensor on the market. The intelligent electronic control delivers quiet and unobtrusive pump operation. All the electronics are fully encapsulated for ultra-reliable operation. The slim design adds to the versatility of pump placement.

Features

- Electronic non-contact sensor for mounting in all positions 0 – 90° angle
- Low noise level of only 20 dB(A) (1 m)
- Pump capacity up to 12 L/hr suitable up to 18 kW units
- Pump head height 5 m
- Electronic soft start and stop of the pump
- Fits in: Split, cassette, fancoil, ducted and ceiling suspended units
- Easy to install in every situation
- A comprehensive installation kit is included.
- CE approved
- Easy installation video on our website
- The original, unique condensate pump with non-contact sensor
- Manufactured and designed in Europe
- And, most important; failure rate < 0,0005%

For Air Conditioners:

Split Systems, Cassette Units, Ceiling Suspended, Fan Coils and Ducted Units

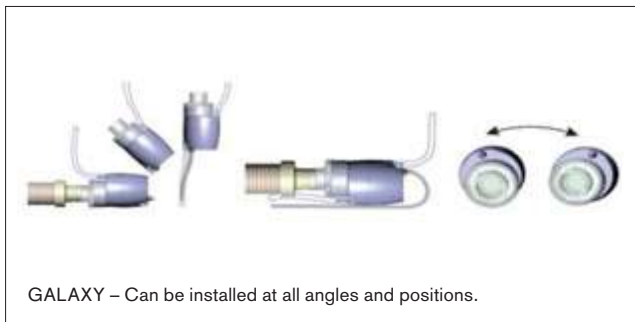

Specifications

Power supply	230 V AC, 50 Hz, 30 W
3A alarm wires, N/O contacts	yes
Class I appliance	yes
Thermally protected Reset 50° C	yes
Encapsulated electronics	yes
Fuse	1 A min, 3 A max.
Maximum water temperature	40 °C
Discharge tube	6 mm i/d
Sensor drain connection	14 to 19 mm
Quiet soft start and switch off	yes
Pumping capacity	

Replacement Parts

Spare Sensor for GALAXY pump	HSG-1000.01S
------------------------------	--------------

CE



CONDENSATE PUMPS



ASTRO

ASTRO

External mount condensate pump

External mount condensate pump with electric operation and sensor. Fast and Simple assembly and Service.

Features

- Ultra reliable Electronic water sensing
- Quiet Soft Start Switch
- Fully electronic operation
- Quick and simple installation
- Fast and simple servicing
- Versatile design allows installation to the right or left side of the A/C indoor unit
- Long life, easy-wash filter protects for longer periods than with wire/plastic mesh
- Large 250 ml collection tray
- Timed Alarm Circuit
- Quiet operation 19 dB noise Level
- Capacity 9 l/h and 6 l/h to 5 m
- Compact just 209 x 59 x 68 mm

Specifications

Power Supply	230 V, 50 - 60 Hz
Capacity	9 l/h, 6 l/h at 5 m
Discharge Lift	max. 10 m
Sound Level	<20 dB(A)
Alarm	3 A Volt free wires
Index Protection	IP30
Dimensions	209 x 59 x 68 mm



CONDENSATE TANK PUMPS

MPS 1 · MPS 2 · MPS 3



MPS 1

MPS 1 · MPS 2 · MPS 3 Condensate Tank Pumps

Features

- Fully automatic trouble free float
- Built in check valve
- Safety Switch for alarm or switch off
- Stainless steel shaft
- Easy installation
- Maximum Ph value (acidity) of condensate water >3,4

Specifications MPS 1

Power Supply	230 V, 50 Hz
Capacity	96 l/h (1 m), 60 l/h (2 m)
Discharge Lift	2 m
Tank Capacity	0,2 l
Dimensions	72 x 170 x 115 mm



MPS 2

Specifications MPS 2

Power Supply	230 V, 50 Hz
Capacity	168 l/h (2 m), 84 l/h (4 m)
Discharge Lift	4 m
Tank Capacity	1,7 l
Dimensions	127 x 282 x 177 mm



MPS 3

Specifications MPS 3

Power Supply	230 V, 50 Hz
Capacity	504 l/h (2 m), 348 l/h (4 m), 216 l/h (6 m)
Discharge Lift	6 m
Tank Capacity	1,7 l
Dimensions	127 x 282 x 177 mm



PROMAX[®]



ROBINAIR[®]

R32

CO₂

R290/
600a

ADDITIONAL INFORMATION THROUGH YOUR SMARTPHONE OR TABLET

This catalogue contains additional information. With your smartphone or tablet you can download it through this page.

Simply more to enjoy:

1. Install the Junaio App for free.
2. Scan with the app the QR-Code
3. Hold your smartphone or tablet over this page.
That's it.



BRIGHT FLAIR FITTING

Flare connectors with renewable copper ring

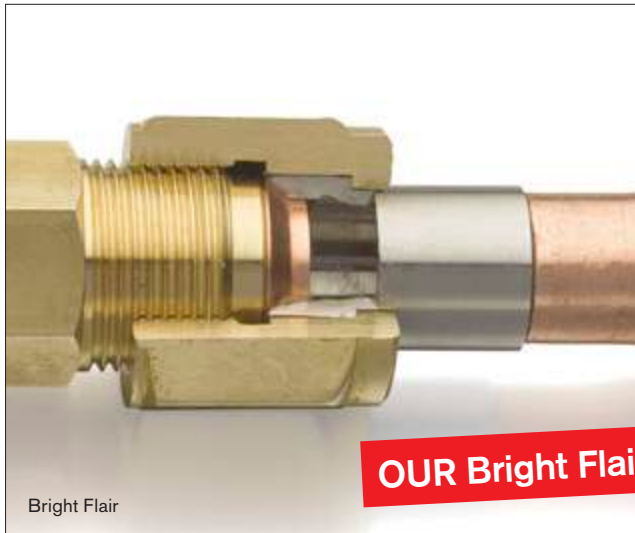

Offering tools to fight the INCONVENIENT TRUTH

Melting poles are caused by global warming due to the greenhouse effect and ozone-layer depletion. Refrigerants penetrating the stratosphere after leaking out of HVAC/R systems are partially responsible for this. Leakage often occurs due to flare connections that seemed perfect but became unreliable in time.

Flares become unreliable due to re-use after component replacement and/or because of stress near the flare from vibrations during the installation's life time. This leads to deformation and cracking of the flare. With a patented solution the flare is replaced by a renewable copper trumpet ring as a seal. Renewing this copper ring after component replacement ensures a new and tight connection. The unique construction of the flare-adaptor avoids tension and force on the "flare-connection". The ring is fully supported and only pressed down on the SAE-seat by a (stainless) steel core. Deformations and cracking of the connection does not occur. The lines are brazed on/to the adaptor with low silver solder.

- Save time and money on maintenance and installation using our flare adaptors
- A wide range of adaptors available
- The soft copper ring, used as a seal and fully supported by a stainless core, is pressed down on the SAE seat by a brass nut with frost grooves

Features

- Reliable connection change from flare into brazing
- High tightness degree
- Easy and fast component replacement (the copper seal must always be renewed)
- The use of frost grooves allows application in wet environments
- Copper/copper brazing with low silver solder
- Easy and clean brazing

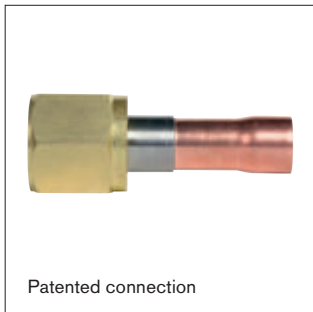

Normal Flare

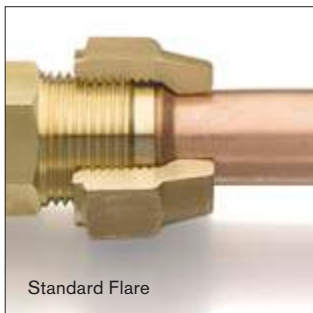

BRIGHT FLAIR FITTING

Flare connectors with renewable copper ring

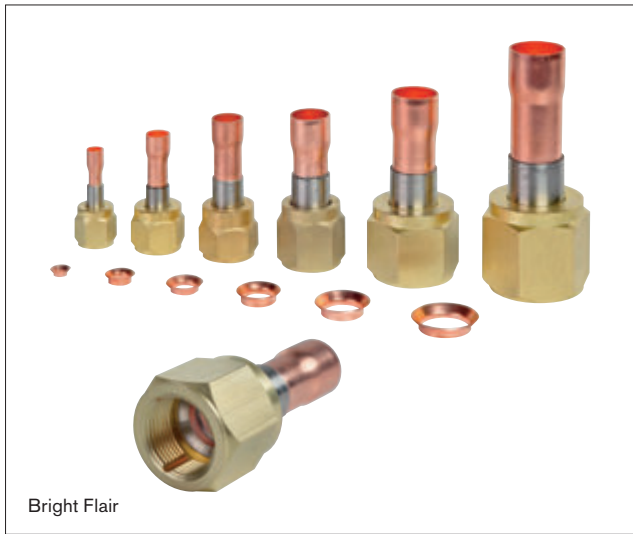

Standard model

- SAE connection to ODF inches (")

Standard model, metric

- SAE connection to ODF millimeters (mm)

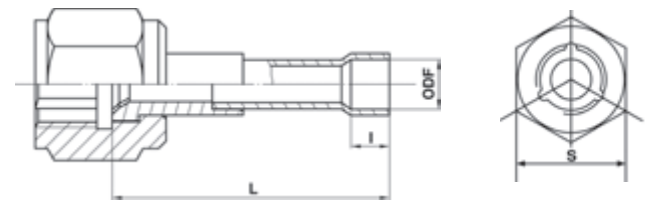

Part number Selection Chart

Part Number	Connection		Dimensions (mm)			Trumpet Ring Copper Ring
	SAE flare	ODF	L	I	S	
RAFL - 1/4"	1/4"	1/4"	45	5	17	RATR - 1/4" - 6
RAFL - 6 mm	1/4"	6 mm				
RAFL - 3/8"	3/8"	3/8"	45	8	22	RATR - 3/8" - 10
RAFL - 10 mm	3/8"	10 mm				
RAFL - 1/2"	1/2"	1/2"	54	9	24	RATR - 1/2" - 12
RAFL - 12 mm	1/2"	12 mm				
RAFL - 5/8"	5/8"	5/8"	57	11	27	RATR - 5/8" - 16
RAFL - 16 mm	5/8"	16 mm				
RAFL - 3/4"	3/4"	3/4"	68	13	36	RATR - 3/4" - 18
RAFL - 18 mm	3/4"	18 mm				
RAFL - 7/8"	7/8"	7/8"	87	14	41	RATR - 7/8" - 22
RAFL - 22 mm	7/8"	22 mm				
RAFL - 3/8" x 1/4"	3/8"	1/4"	45	6	22	RATR - 3/8" - 10

TUBE CUTTERS

ROBINAIR®

RA TC10001 · RA TC10002

Smart SpringSM Tube Cutters



RA TC10001 · RA TC10002

Robinair has introduced an all new advanced Tube Cutter that automatically adjusts as a tube is cut. Now you no longer need to manually tighten the cutter after each rotation - the RA TC10001/10002 does it for you - automatically!

Available with either a standard Nickel-plated cutting wheel (model RA TC10002), or our unique, super-hard, Titanium wheel (model RA TC10001) for extreme durability and life.

Features

- Patented Design
- Smart SpringSM mechanism automatically cuts tubing
- Releases unnecessary pressure from the cutting wheel
- Stabilizes tracking of cutting wheel for spiral free cuts
- Automatically adjusts for easy cutting of out-of-round tubes
- Blades are thinner and sharper than standard – allows easier cutting; Silver blade is Nickel, Gold is Titanium
- Can be used on tubing from 1/8" to 1 1/8" (4 to 28 mm) in diameter
- Spring tension is adjustable for various pipe thicknesses from 0.5 to 1.5 mm
- Precision rollers with flare cut-off groove
- Includes spare cutting wheel stored in handle
- Overall Length 130 mm
- Weight 250 g

Optional Accessories

RA TC11	Titanium Wheel Gold – For RA TC10001
RA TC12	Nickel Wheel Silver – For RA TC10002



Simple Operation

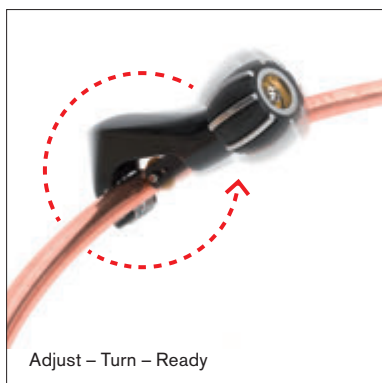

Adjust – Turn – Ready



RA TC11 · Titanium



RA TC12 · Nickel



TUBE CUTTERS



174-F "BIG IMP®"

Tube Cutter for Metal Tubing

"Big capacity in small size"

Features

- For 3/8" to 1-1/8" (10 to 28 mm) O.D. tubing
- Includes two S75015 general-purpose cutter wheels
- Swing radius 1-15/16" (2-1/4" swing radius with 1-1/8" tube)
- Length 2-11/16" (7 cm)
- Weight 140 g

Replacement Parts

- TC-1A Cutter Wheel (Set of 3) – S75015
1 Screw – S74762
- TC-1B Cutter Wheel (Set of 3) – S75046
1 Screw – S74765, Stainless Steel
- S74762 Cutter Wheel Retaining Screw (Set of 5)



206-FB

Adjust-O-Matic® Tube Cutter for Metal Tubing

For 3/8" to 2-5/8" tubing.

Features

- Ratchet feed mechanism speeds up cutting operation
- Extra wide rollers with flare cut-off groove to stabilize tubing
- Spare cutting wheel included under handle cap
- Enclosed screw-type feed mechanism; light weight aluminum alloy body
- For 3/8" to 2-5/8" and 10 to 66 mm O.D. tubing
- Includes two S74761 general-purpose cutter wheels
- Length closed 7-3/4" (20 cm)
- Weight 910 g

Replacement Parts

- S74761 Cutter Wheel (Set of 5)
- S77511 Cutter Wheel Retaining Screw

TUBE CUTTERS



312-FC

TC-1000 / TC-1010 / 312-FC Hi-Duty® Tube Cutter for Metal Tubing

For 1/8" to 1-1/8" and 1/4" to 1-5/8" O.D. tubing.

Features

- Enclosed hardened steel, thrust bearing feed mechanism for smoothest cutting action and trouble free operation
- Imperial's unique design eliminates spiraling for clean right angle cuts. Our high precision machining and construction method permits one-piece screw type axle for easy access to cutting wheel - no clip to lose or replace
- Rugged aluminum alloy body designed for handling ease. Body is hand buffed and nickel chrome plated to a high luster finish
- Foldaway hardened steel reamer with turned cutting edge removes inside burrs cleanly. Filing surface removes outside burrs
- Rollers feature flare cut-off groove to reduce tube loss when damaged flare is removed
- Imperial cutter wheels are made of the highest quality wear & abrasion resistant chromium steel and precision machined to exacting specifications for accurate cutting and long life. Each tool is supplied with a spare cutter wheel
- All Imperial tube cutters are 100 % factory tested to ensure accurate spiral free cutting

TC-1000	For 1/8" to 1-1/8" (4 to 28 mm) O.D. tubing. Includes (2) S75015 general-purpose cutter wheels. Length 5" (13 cm), Weight 180 g
TC-1010	Suitable for Stainless Steel tubing for diameter 1/8" to 1-1/8" (4 to 28 mm) O.D.F. Includes (2) S75046 spare cutting wheel. Length 13 cm, Weight 185 g
312-FC	For 1/4" to 1-5/8" (7 to 41 mm) O.D. tubing. Includes (2) S75015 general-purpose cutter wheels. Length 5-1/2" (14 cm), Weight 200 g

Replacement Parts

- TC-1A Cutter Wheel (Set of 3) – S75015 · 1 Screw – S74762
- TC-1B Cutter Wheel (Set of 3) – S75046 · 1 Screw – S74765, Stainless Steel
- S74762 Cutter Wheel Retaining Screw (Set of 5)
- S75015 General Purpose Cutter Wheel (Set of 10)



TUBE CUTTERS



406-FA

406-FA

Adjust-O-Matic® Tube Cutter for Metal Tubing

For 2" to 4 1/8" (51 to 104 mm) O.D. tubing.

Features

- Ratchet feed mechanism speeds up cutting operation
- Extra wide rollers with flare cut-off groove to stabilize tubing
- Spare cutting wheel included under handle cap
- Enclosed screw-type feed mechanism; light weight aluminum alloy body
- For 2" to 4-1/8" and 51 to 104 mm O.D. tubing
- Includes two S74833 general-purpose cutter wheels
- Length closed 11" (29 cm)
- Weight 1600 g

Replacement Parts

- S74833 Cutter Wheel (Set of 3)
- S74834 Cutter Wheel Retaining Screw (Set of 3)



RA 42024

RA 42024

ROBINAIR Mini Tubing Cutter



Features

- Short swing radius
- For extreme tight spots
- Wide capacity range
- For 1/8" to 1-1/8" O.D. tubing

TUBE CUTTERS



TC-1050-IMP

TC-1050 IMP®

Mini Tubing Cutter for Metal Tubing

For 1/8" to 5/8" O.D. tubing.

Features

- Big capacity, small size tube cutters designed for use in tight quarters where other cutters won't fit
- Enclosed feed screw minimizes contamination assuring continued smooth operation
- Corrosion resistant stainless steel rollers positioned at bottom of cutter allows for easier cutter engagement on tubing and smoother cutting action
- All Imperial tube cutters are 100% factory tested to ensure accurate spiral free cutting
- For 1/8" to 5/8" and 4 to 15 mm O.D. tubing
- Includes one S32633 general-purpose cutter wheel
- Swing radius 1-1/4"
- Length 1-3/4" (4,5 cm)
- Weight 70 g

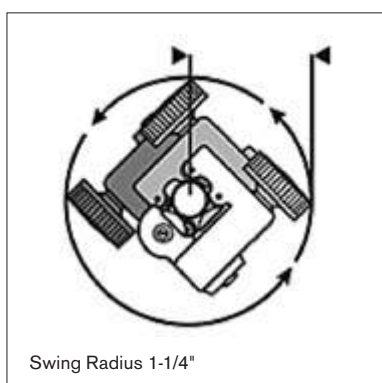

Swing Radius 1-1/4"

Replacement Parts

- TC-1C Cutter Wheel (Set of 2) – S32633
- 1 Screw – S26883



TC-1050-RH

TC-1050-RH

Ratcheting Mini Tube Cutter

For 1/8" to 5/8" and 4 to 15 mm O.D. tubing.

Features

- Minimal clearance radius of 1-1/4"
- Easily completes a full revolution, maximizing leverage
- TC-1050 RH cutter can easily be removed from the handle. Includes one S32633 general purpose cutter wheel
- Ergonomic handle with non-slip grip
- 100 % factory tested to ensure accurate spiral-free cutting
- Six independent drive pawls provide 15° arc-swing
- 5" (13 cm) nominal length

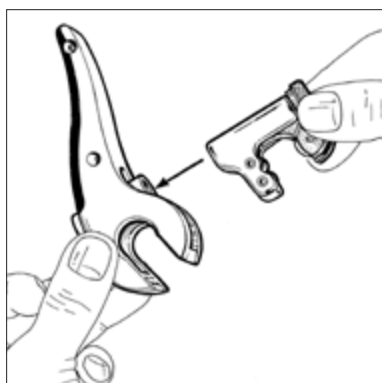

TUBE CUTTERS



TC-1550

TC-1550 Hi-Duty™ Tube Cutter

For 1/8" to 1-1/8" (4 to 28 mm) O.D. tubing.

Features

- Lower profile swing radius – 4-1/4"
- Retractable rotary style reamer – can be used right- or left-handed, and with a clockwise or counterclockwise motion for better ergonomic control
- Rollers feature flare cut-off groove to reduce tube loss when damaged flare is removed
- Lightweight die-cast solid aluminum body – lighter than similar cutters
- Imperial's unique design eliminates spiraling for clean right angle cuts
- Our high precision machining and construction method permits one-piece screw-type axle for easy access to cutting wheel – no clip to lose or replace
- Imperial cutter wheels are made of the highest quality wear and abrasion-resistant chromium steel and precision machined to exacting specifications for accurate cutting and long life. Each tool is supplied with a spare cutter wheel.
- Available in "Try Me" clamshell packaging (TC-1550C)

Replacement Parts

- S75015 General Purpose Cutter Wheel (Set of 10)

TUBE BENDERS



AC Smart Bender

AC SMART BENDER

Pre insulated Copper Tubing Bender 1/4" x 3/8" (6 x 10 mm)

Finally, a quick, easy and reliable way to make perfect bends every time for copper tubing pairs at wall outlets. The Robinair AC Smart Bender is a specially designed tool that allows you to make beautiful tight bends, by hand, right against a wall anywhere you are bringing out a copper tube pair. This clever device eliminates any possibility for kinks or damage to the tubes and makes a neat and professional job, quickly and easily every time.

Features

- Easy to use
- Requires no experience or other tools
- Works with 1/4" and 3/8" copper tube pairs
- Ensures the tightest possible bends
- Eliminates kinks or damage to tubes
- 3 simple steps yield perfect results every time
- Durable ABS construction
- Lightweight, compact and completely portable, always have it on hand

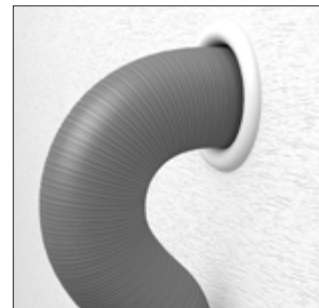
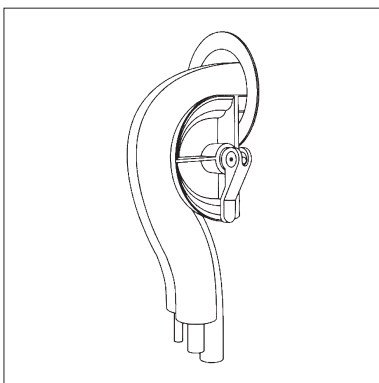
NEW

TUBE BENDERS



102-F-06

102-F-04 / 05 / 06 / 08 / 10 / 12 Spring Type Tube Benders

For soft copper and aluminum tubing. For 3/8" to 3/4" O.D. tubing.

Tools allow hand bending of soft tubing to any shape without collapsing walls. Special spring steel, zinc finish. End belled for quick tube removal.

Item	Tube O.D.	Length	Weight each
102-F-04	1/4"	254 mm (10")	0,08 kg
102-F-05	5/16"	254 mm (10")	0,08 kg
102-F-06	3/8"	254 mm (10")	0,11 kg
102-F-08	1/2"	305 mm (12")	0,18 kg
102-F-10	5/8"	305 mm (12")	0,23 kg
102-F-12	3/4"	305 mm (12")	0,28 kg



364-FHA-10

364-FHA Lever Type Tube Benders

For 1/8" to 1" (6 to 12 mm) O.D. tubing.

Each tool bends one size. Open side type which slips over tube at any point. Makes smooth, tight radius bends up to 180° with minimum effort. No scoring or flattening of tubing. Calibrated to show angle of bend. Wide hook grips tubing securely.

Item	Tube O.D.	Radius to Center of Tube	Weight each
364-FHA-04	1/4"	9/16" (14 mm)	0,45 kg
364-FHA-06	3/8"	15/16" (24 mm)	0,8 kg
364-FHA-08	1/2"	1-1/2" (38 mm)	1,6 kg
364-FHA-10*	5/8"	2-1/4" (57 mm)	2,5 kg
364-FHA-12*	3/4"	3" (76 mm)	3,2 kg
364-FHA-14*	7/8"	3" (76 mm)	4,76 kg

Each tool bends only one size. Conforms to Federal Specifications GGG-B-191a Type III, Class 2.

*For bending annealed copper and aluminum tubing only.

Metric Size Bending Tools	Tube O.D.	Radius to Center of Tube	Weight each
364-FHAM-10	10 mm	15/16" (24 mm)	0,80 kg
364-FHAM-12	12 mm	1-1/2" (38 mm)	1,60 kg

TUBE BENDERS



364-FHB-06

364-FHB Swivel Handle Tube Benders

For 1/4" to 1/2" (6 to 12 mm) O.D. tubing.

The patented 364-FHB series has a swivel handle that can be repositioned midway through a bend when both handles begin to meet. This simple feature allows easy fabrication of bends up to 180° with reduced effort, better control and without the crossing of handles, typical of most other lever type benders.

Item	Tube O.D.	Radius to center of tube	Weight each
364-FHB-04	1/4"	9/16" (14 mm)	0,45 kg
364-FHB-06	3/8"	15/16" (24 mm)	0,80 kg
364-FHB-08	1/2"	1-1/2" (38 mm)	1,60 kg

Metric Size Bending Tools	Tube O.D.	Radius to center of tube	Weight each
364-FHBM-6	6 mm	9/16" (14 mm)	0,45 kg
364-FHBM-10	10 mm	15/16" (24 mm)	0,80 kg
364-FHBM-12	12 mm	1-1/2" (38 mm)	1,60 kg



367-FH

367-FH / 368-FH IMP® Triple-Head Benders

For soft copper, aluminum and thin wall steel tubing. For 1/8", 3/16", 1/4", 5/16", 3/8" O.D. tubing. Makes up to 90° bends.

Calibrated markings for making accurate left-hand, right and offset bends. Ninety degree start requires less effort – making bending fast and easy. For soft copper, aluminum and steel.

367-FH	For 1/8", 3/16" and 1/4" (3, 4 and 6 mm) O.D. tubing. Weight 0.2 kg
368-FH	For 3/16", 1/4", 5/16" and 3/8" (6 and 8 mm) O.D. tubing. Weight 0.450 kg



368-FH



TUBE BENDER



370-FH

370-FH

Triple-Head 180° Tube Bender

Bend 3 of the most popular sizes of soft copper, aluminum and thin wall steel tubing with one rugged, precise tool!

Features

- Bends 1/4", 3/16", 3/8" and 1/2" Tubing
- Makes Smooth, Tight Radius 180° Bends
- Calibrated Markings - for making accurate left-hand, right-hand and offset bends
- Adjustable hook
- Optimum Bending Radius - for each tubing size
- Cushion Grips - for extreme comfort
- Made of Lightweight Die-Cast Aluminum

Tube O.D.	Radius to center of tube
1/4"	11/16" (1,75 cm)
3/16"	11/16" (1,75 cm)
3/8"	1-1/8" (2,85 cm)
1/2"	1-1/2" (3,81 cm)

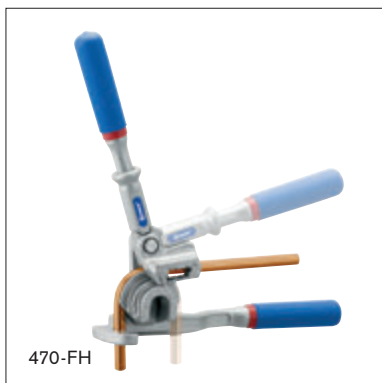

470-FH

470-FH

Triple head Bender with Roto-Lok™

Triple head 180° Tube Bender with Roto-Lok™ Indexing Handle.

Features

- Bends 3/16", 1/4", 5/16" and 3/8" O.D. Tubing
- Patented, quick-action indexing lever repositions two-stage handle midway through bend when both handles begin to meet. This feature allows easy fabrication of bends up to 180° with reduced effort, better control and no crossing of handles
- Optimum Bending Radius – for each tubing size
- Calibrated markings – for making accurate left-hand, right-hand and offset bends
- Compact design for working in tight spaces
- Cushion grips – for comfort and stability
- Made of lightweight, die-cast aluminum
- Available in "Try Me" clamshell packaging (470-FHC)

Tube O.D.	Radius to center of tube
3/16"	9/16" (14 mm)
1/4"	9/16" (14 mm)
5/16"	11/16" (17 mm)
3/8"	15/16" (24 mm)

TUBE BENDER



270-F-14 · 270-F-18 Gear Type Tube Bender

For 7/8" and 1-1/8" (22 and 28 mm) O.D. tubing.

For all bending work. Spur-gear type with 10-to-1 ratio for easy bending of all tempered tubing. Floating shoe aligns tube perfectly on calibrated forming wheel. Pull-pin on wheel speeds repositioning for bends over 90°. Portable. Can be hand held, clamped in vise or bolted to bench. Adapts to pipe vise with handle 271-F.

Item	Tube O.D.	Radius from center to center of tube	Min. Return from center to center of tube	Weight each	Wall thickness
270-F-14	7/8"	4"	9-1/2"	6,7 kg	0,045" to 0,083"
270-F-18	1-1/8"	4"	9-1/2"	6,7 kg	0,065" to 0,095"

FLARING / SWAGING TOOLS



175EX XpandR™ Swaging / Expanding Kit

Features

- Easily expands tube for braze & soldered joints in seconds
- Floating jaw head design is self-centering for fast, accurate alignment
- Re-rounds deformed tube ends
- Accurate joints in seconds without using fittings
- For soft copper and soft thin wall steel and stainless steel tubing
- Long life with high alloy hardened steel jaw segments
- Supplied in a compact carrying case
- Includes 5 heads: 3/8", 1/2", 5/8", 3/4" and 7/8"

175EX Kit includes

175EXP	XpandR™ Pliers
175EXC	XpandR™ Case
175EX06	3/8" head
175EX08	1/2" head

175EX10	5/8" head
175EX12	3/4" head
175EX14	7/8" head

Additional head sizes available

175EX16	1" head
175EX18	1-1/8" head

175EX22	1-3/8" head
175EX26	1-5/8" head



FLARING / SWAGING TOOLS



195-FC

195-FC 45° Flaring Tool

For 3/16", 1/4", 5/16", 3/8", 7/16", 1/2" and 5/8" O.D. tubing.

Flares 7 sizes of tubing. Rugged forged steel slip-on yoke and hardened flaring bar. Positive clamping action of bars prevents tube slippage. Self centering yoke with swivel-type, hardened steel, chrome finished flaring cone forms better flares with less effort. Design of yoke permits flaring where there is little space between nut and tube end. Satin finish nickel-chrome plated. Weight 0.907 kg.

Tube O.D.	3/16"	1/4"	5/16"	3/8"	7/16"	1/2"	5/8"
Wall Thickness	.028"	.035"	.035"	.035"	.035"	.035"	.035"



275-FS

275-FS Flaring (45°) & Swaging Tool

For 1/8" to 3/4" O.D. tubing.

Flares 1/8", 3/16", 1/4", 5/16", 3/8", 7/16", 1/2", 5/8" and 3/4" O.D. Includes 5 swage adapters that swage 7 tube sizes 3/16", 1/4", 5/16", 3/8", 1/2", 5/8", 3/4" O.D.

Features

- Flares and swages
- Converts quickly. Screw-type feed
- Ideal for use in close quarters
- Two bars included cover 9 sizes
- Swivel-type swaging adapters and flaring cone are hardened steel chrome-finished for easy operation
- Self-centering, slip-on forged steel yoke
- Includes carrying/storage case
- Weight 1,6 kg

Replacement Parts

278-FS-03x04x06	Adapter 3/16", 1/4", 3/8"
278-FS-05	Adapter 5/16"
278-FS-08	Adapter 1/2"
278-FS-10	Adapter 5/8"
278-FS-12	Adapter 3/4"
S38600	Flaring Cone

FLARING / SWAGING TOOLS



275-FSM

275-FSM

Metric Flaring (45°) & Swaging Tool

For 4 to 22 mm O.D. tubing.

Suitable for tube sizes 4 mm, 6 mm, 8 mm, 10 mm, 12 mm, 14 mm, 15 mm, 16 mm, 18 mm and 22 mm outside diameter.

Features

- Flares and swages
- Converts quickly. Screw-type feed
- Ideal for use in close quarters
- Two bars included cover 10 sizes
- Swivel-type swaging adapters and flaring cone are hardened steel chrome-finished for easy operation
- Self-centering, slip-on forged steel yoke
- Includes carrying/storage case
- Weight 1,6 kg

Tube O.D.	4 mm	6 mm	8 mm	10 mm	12 mm
Wall Thickness	1,0 mm	1,0 mm	1,0 mm	1,0 mm	1,0 mm
Tube O.D.	14 mm	15 mm	16 mm	18 mm	22 mm
Wall Thickness	1,0 mm	1,0 mm	1,0 mm	1,0 mm	1,0 mm

Replacement Parts

278-FSM-4-6-10	Adapter 4 mm, 6 mm, 10 mm	278-FSM-15	Adapter 15 mm
278-FSM-8	Adapter 8 mm	278-FSM-16	Adapter 16 mm
278-FSM-12	Adapter 12 mm	278-FSM-18	Adapter 18 mm
278-FSM-14	Adapter 14 mm	278-FSM-22	Adapter 22 mm
		S38600	Flaring Cone



275-FSC

275-FSC

45° Flaring, Cutting and Swaging Kit

For soft copper, aluminum, steel, stainless steel and brass tubing.

Kit contains a TC-1000 tube cutter for 1/8" to 1-1/8" O.D. tubing and 275-FS 45° flaring and swaging tool. In tool case. Weight 1.361 kg.

Flares: 1/8", 3/16", 1/4", 5/16", 3/8", 7/16", 1/2", 5/8" and 3/4" O.D. tubing.

Swages: 3/16", 1/4", 5/16", 3/8", 1/2", 5/8" and 3/4" O.D. tubing.



FLARING / SWAGING TOOLS



500-FC

500-FC 45° Rol-Air Flaring Tool

Flares and burnishes 3/16", 1/4", 5/16", 3/8", 1/2" and 5/8" O.D. tubing.

Faceted, hardened steel, chrome-finished cone rolls out perfect 45° flares above die block, and automatically burnishes flare face reducing the need for deburring. Original wall thickness is maintained at base of flare. New slip-on yoke permits use in tight quarters, where there is little space between nut and tube end. Larger handle, with better leverage, and precision threads on feed screw make flaring effortless. Heat treated dies grip tubing without scoring. Satin chrome and black finish. Weight 680 g.

Tube O.D.	3/16"	1/4"	5/16"	3/8"	1/2"	5/8"
Wall Thickness	.028"	.035"	.035"	.035"	.035"	.035"



500-FCM

500-FCM Metric Size 45° Rol-Air Flaring Tool

Flares and burnishes 6, 8, 10, 12, 15 and 16 mm O.D. tubing.

Faceted, hardened steel, chrome-finished cone rolls out perfect 45° flares above die block, and automatically burnishes flare face reducing the need for deburring. Original wall thickness is maintained at base of flare. New slip-on yoke permits use in tight quarters, where there is little space between nut and tube end. Larger handle, with better leverage, and precision threads on feed screw make flaring effortless. Heat treated dies grip tubing without scoring. Satin chrome and black finish. Weight 680 g.

Tube O.D.	6 mm	8 mm	10 mm	12 mm	15 mm	16 mm
Wall Thickness	1,0 mm	1,0 mm	1,0 mm	1,0 mm	1,0 mm	1,0 mm

FLARING / SWAGING TOOLS



525-F

525-F

"Grabber"[®] 45° Rol-Air Flaring Tool

Universal application. Adjustable opening holds all sizes. Flares and burnishes 3/16" to 5/8" (4.75 to 16 mm) O.D. tubing.

Unique, self-adjusting, tube holding mechanism permits flaring any size tubing within the range of 3/16" to 5/8" (4.75 to 16 mm) O.D. tubing. Innovative, single opening design is more compact and easier to use than conventional multi-opening flaring bars. Faceted, hardened steel, chrome-finished cone rolls out and burnishes perfect 45° flare above the tube holding mechanism reducing need for deburring. Original wall thickness is maintained at base of flare. Slip-on self-centering yoke permits use in tight quarters. Large handle, with better leverage, and precision threads on feed screw make flaring effortless. High quality construction with satin chrome and black finish. Weight 800 g.

Tube O.D.	4,75 mm	6 mm	8 mm	10 mm	12 mm	15 mm	16 mm
Wall Thickness	1,0 mm	1,0 mm	1,0 mm	1,0 mm	1,0 mm	1,0 mm	1,0 mm

Tube O.D	3/16"	1/4"	5/16"	3/8"	1/2"	5/8"
Wall Thickness	.028"	.035"	.035"	.035"	.035"	.035"



RA 801E

RA 801E

Eccentric Flaring Tool

ROBINAIR[®]

Features

- Eccentrically mounted hardened steel flaring cone provides for smooth easy flare walls
- Makes perfect 45° Flares every time
- Solid die cast aluminum body yoke and steel die block
- Hinge action die bar opens and closes quickly and easily for fast set-up
- Indicator mark and yoke clamp for correct positioning over tubing
- Can be used on copper or aluminum tubing
- Fits 6 different sizes of tubing – 1/4", 5/16", 3/8", 1/2", 5/8" and 3/4"
- Also available for metric tubing 6, 8, 10, 12, 16 and 18 mm tubing.
Order P/N RA801E-Metric
- Packed in a protective blow molded case with extra storage
- Weight 1.3 kg



FLARING / SWAGING TOOLS



193-S

193-S

Punch Type Swaging Tools

Use these tools for making tubing connections without fittings. Enlarge end of tube, insert another tube of original O.D. size and solder together like a sweat fitting. Vinyl case contains 4 swaging punches 1/4", 3/8", 1/2" and 5/8" O.D. tubing. Weight 450 g.

Individual Swaging Tools

Item	Tube O.D.	Wall Thickness	Weight
93-S-04	1/4"	.035"	90 g
93-S-06	3/8"	.035"	113 g



95-S

95-S

Punch Type Swaging Tool

Use this tool for making tubing connections without fittings. Enlarge end of tube, insert another tube of original O.D. size and solder together like a sweat fitting.

Features

- One tool swages 3/16", 1/4", 5/16", 3/8", 1/2", 5/8" O.D. tubing
- Hi-alloy steel, heat-treated for rugged use
- Hex head design for ease of extraction
- Precision machined surface for ease of forming

Tube O.D.	3/16"	1/4"	5/16"	3/8"	1/2"	5/8"
Wall Thickness	.028"	.035"	.035"	.035"	.035"	.035"



DEBURRING TOOLS



208-F

208-F

Inner-/Outer Reaming And Deburring Tool

Features

- For 3/16" to 1-1/2" OD tubing
- Reams both inside and outside edges of tube with 3 hollow ground cutters
- Tough die cast body
- Deburrs both clockwise and counterclockwise
- Fluted body is shaped to fit comfortably in palm
- Reamer for copper, aluminum and brass tubing
- Hardened steel cutter blades
- Blue finish
- Weight 285 g



208-F

210-F

Deburring Tool

Rotary style blade is perfect for removing burrs from holes and edges of any size. Large ergonomic handle reduces user fatigue, includes handy storage cavity for extra blades. Ships complete with two heavy duty blades for copper, steel, aluminum, zinc, cast iron, brass and plastic tubing.





RATCHET WRENCHES



124-C

124-C Ratchet Wrench

Combination wrench with the four sizes most needed for servicing air-conditioning and refrigerator equipment.

9/16"	Hex for dust cap on access valves and oil check plug on compressor
1/2"	Hex for compressor mounting bolts
1/4"	Square for valve stem and service valves and old style compressor valves
3/16"	Square for refrigerant charging tank valves



125-C

125-C Ratchet Wrench

Rugged, steel forged wrench with four sizes covering almost any application. Ratchet has 1/4" drive on one end; other end has 3/16" and 5/16" square openings, plus 9/16" hex opening.

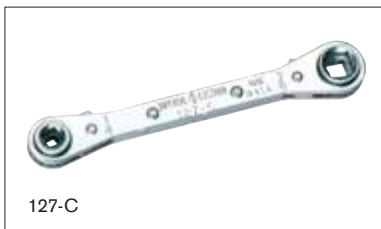

127-C

127-C Ratchet Wrench

Compressor access valve wrench. Chrome plated. Has 1/4", 3/8", 3/16" and 5/16" square drive ratchets and is specially designed for use on compressors with access valves in hard to reach places. Reversible ratchets.



127-CO

127-CO WITH 25° OFFSET Ratchet Wrench

Same as 127-C except with unique 25° offset that provides additional convenience in hard to reach places.



RA 10696

RA 10696 Ratchet Wrench

Reversible, four **square** openings, 1/4" and 3/16" on one end, 3/8" and 5/16" on the other.

ROBINAIR VALVE TOOLS

ROBINAIR®

RA 13145

RA 13145**ROBINAIR 1/4" Valve Core remover / installer**

Includes 6 replacement valve cores.



RA 18561

RA 18561**ROBINAIR Valve Core remover / installer 1/4" (7/16" UNF)**

Replace leaking valve cores quickly and easily, or remove the valve core and hold it out of place for evacuation or charging. Features a solid brass body with a convenient handle that opens and closes in a quarter-turn to speed service. Compact design easily fits most locations. Connection: 1/4" SAE

Replacement Parts

RA 45500	Replacement Kit Seals
----------	-----------------------



RA 18565

RA 18565**ROBINAIR Valve Core remover / installer 5/16" (1/2" UNF)****R410A**

Replace leaking valve cores quickly and easily, or remove the valve core and hold it out of place for evacuation or charging. Features a solid brass body with a convenient handle that opens and closes in a quarter-turn to speed service. Compact design easily fits most locations. Connection: 5/16" SAE



RA 40288

RA 40288**ROBINAIR Piercing Valve****Features**

- Piercing valve with flow control
- 1/4 SAE connector size
- Fits copper tubing with 3/16", 1/4", 5/16" O.D.



ROBINAIR VALVE TOOLS



RA 40330 · RA 40336

ROBINAIR Piercing Valves with Valve Cores

RA 40330	Fits 3/16", 1/4", 5/6", 3/8" Tube O.D.
RA 40336	Fits 1/2", 5/8" Tube O.D.

ROBINAIR FITTINGS



RA 40352

ROBINAIR Valve Cores

Package of 6 pieces



TEES

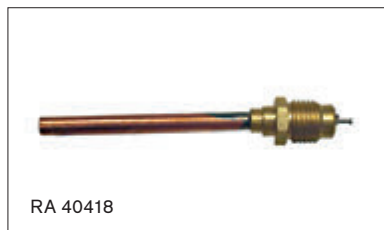

RA 40384	1/4" MFL Branch with core x 3/8" OD tube or 1/2" OD solder (Set of 3)
RA 40386	1/4" MFL run x 1/4" FFL run with depressor x 1/4" MFL Branch with core (Set of 3)
RA 40390	1/4" MFL Branch with core x 1/8" MPT run x 1/8" MPT (Set of 3)
RA 40396	1/4" MFL Branch with core 1/4" MFL run x 1/4" FFL swivel run (Set of 3)
RA 40398	1/4" FFL Swivel Branch with depressor x 1/4" MFL run with core x 1/4" MFL run (Set of 3)
RA 40399	1/4" FFL Swivel Branch x 1/4" MFL run x 1/4" MFL run with core (Set of 3)
RA 40423	1/8" MPT Branch x 1/4" MFL run x 1/4" MFL run with core (Set of 3)
RA 50396	1/4" MFL Branch with core 1/4" MFL run x 1/4" FFL swivel run (1 piece)

Solder Union Type

RA 40416	1/4" MFL x 1/8" OD Copper Tube Ext. (Set of 6)
RA 40418	1/4" MFL x 1/4" OD Copper Tube Ext. (Set of 6)

Straight Swivel Fitting

RA 40560A	1/4" MFL x 1/4" FFL
-----------	---------------------

REPLACEMENT PARTS AND TOOLS

ROBINAIR®

RA 40572

RA 40572

ROBINAIR Brass Caps

RA 40572	1/4" solid brass caps (Set of 6)
----------	----------------------------------



RA 14388

RA 14388

ROBINAIR Refrigerant Oil-Pump

Features

- Oil-Pump design allows you to add refrigerant oil to a system under pressure
- Designed for larger systems
- Siphon hose allows for the removal of old oil, preventing over-charging
- Pump universally mounts directly to one-gallon containers
- Allows the pumping of oil directly from the container, keeping oil free from dirt & moisture
- Pump can remain mounted on oil container during storage
- Oil is pumped at a rate of 90 ml (3 oz) per stroke

Replacement Parts

RA 18171	Replacement Seal
----------	------------------



RA 18403

RA 18403

ROBINAIR Fin Straightener Set

Features

- Clean and straighten condenser and evaporator coil fins
- Compact Design for confined spaces
- Set of 2 wheels provides 12 clearly marked combs:
 - Wheel 1: 8, 9, 10, 12, 14 & 15 fins per inch
 - Wheel 2: 10.5, 11, 13, 18, 20 & 22 fins per inch





RA-SVOM-18

Applications

Suitable for all industrial and commercial systems – where solenoid valves are used.

RA-SVOM-18

ROBINAIR Solenoid Valve Operating Magnets

The solenoid valve operating magnet enables service engineers to operate electric solenoid valves like hand-operated valves.

Features

- Pocket sized and easy to use
- Permanent magnet moulded in ABS plastic
18 mm diameter fits most common solenoids
- Converts electrically operated solenoid valves into hand operated valves in seconds
- Safe design that fits all makes of solenoid valve
- Saves service engineer's time
- The ideal addition to the professional engineer's toolkit
- Bright orange color for high visibility

Specifications

Height	24.5 mm
Diameter	41.0 mm tapered to 18.0 mm
Bore Size	18.0 mm
Magnet	Permanent Magnet



PT-109

PT-109 KWIK-VISE®

Line piercing / refrigerant recovery tool

Line piercing/refrigerant recovery tool pierces, seals and locks on to copper lines in one swift motion. Self adjusting! No need to adjust the tool for different sizes of tubing. The patented tension system automatically locks pliers on copper tubing 1/4" to 1/2" (6 to 12 mm) O.D.. To use simply position the PT-109 on the tubing to be pierced. Close the pliers quickly and firmly. The pliers will automatically adjust and lock into a tightly sealed, secure position.

Features

- Replaceable hardened, stainless steel pierce and brass valve assembly
- Capacity: 1/4" thru 1/2" O.D. refrigerant copper tubing
- Durable: made with high carbon, heat treated, steel jaws
- Works with all refrigerants CFC, HFC, HCFC including Zeotropes and Azeotropes
- 90° elbow valve eliminates tangling and interference problems

Replacement Parts

S10000539	Replacement Seal
S16002045	Replacement Piercing fitting

TIF 175

TRMS AC/DC Clamp-On Ammeter DMM



TIF 175

Replacement Parts

TIF 4413-2	Replacement Test Leads
TIF TK101	Type-K Thermocouple probe



Features

- DC and True RMS AC voltage and current measurements up to 600 V
- Non-contact voltage sensor integrated into clamp
- Also includes Resistance, Frequency, Diode Test, Capacitance, Data Hold, MIN/MAX and Relative readings
- Bargraph, Backlight display & Auto Power Off
- Temperature reading with Type-K probe
- CAT IV, 600 V

Specifications

TRMS	yes
Voltage AC	1 mV - 1000 V
Voltage DC	±1.0 % rdg ±4 digits
Voltage Resolution	0.01 mV - 1000 V
Voltage Accuracy	±1.0 % rdg ±3 digits
Current AC	0.01-600A
Current DC	0.01-600A
Current Accuracy	±2.0 %rdg ±8 digits
Frequency	0.01 Hz - 60 kHz
Frequency Accuracy	±1.0% rdg ±5 digits
Resistance	0.1 Ω - 60 MΩ
Resistance Accuracy	±1.0 % rdg ±5 digits
Continuity Test	yes
Capacitance	0.1 nF - 4 mF
Diode Test	yes
Temperature	-20 - 760 °C
Non-Contact Voltage	yes
Duty Cycle	yes
Data Hold	yes
Bargraph	yes
Relative Measurement	yes
MAX/MIN readings	yes
Peak Hold	yes
Backlight	yes
Auto Power Off	yes
Power Supply	1 x 9 V battery
Battery Life	max. 200 hours
Display	4 Digit LCD
Safety	IEC/EN 61010-1
Measuring Category	Cat IV, 600 V Cat III, 1000 V
Size / Weight	210 x 75 x 45 mm / 400 g
Max. Dia of wire	30 mm



TIF 150

AC Clamp-On Ammeter DMM



TIF 150

Replacement Parts

TIF 4413-2	Replacement Test Leads
------------	------------------------

Features

- Inductive Clamp-on DMM for AC/DC Volts and AC Current up to 600 A
- Non-contact volt sensor integrated into clamp
- Also includes Resistance, Frequency, Diode Test, Capacitance, Data Hold and MAX reading
- Backlight display
- Auto Power off
- CAT IV, 600 V

Specifications

Voltage AC	1 mV - 600 V
Voltage DC	±1.0 %rdg ±4 digits
Voltage Resolution	0.1 mV - 600 V
Voltage Accuracy	±1.0 % rdg ±3 digits
Current AC	1 mA-600A
Current Accuracy	±2.5 %rdg ±4 digits
Resistance	0.1 Ω - 20 MΩ
Resistance Accuracy	±1.0 % rdg ±5 digits
Continuity Test	yes
Diode Test	yes
Non-Contact Voltage	yes
Data Hold	yes
MAX/MIN readings	MAX only
Backlight	yes
Auto Power Off	yes
Power Supply	1 x 9 V battery
Battery Life	max. 200 hours
Display	3½ Digit LCD
Safety	IEC/EN 61010-1
Measuring Category	Cat IV, 600 V Cat III, 1000 V
Size / Weight	210 x 75 x 45 mm / 400 g
Max. Dia of wire	30 mm



TIF 230

Pen Type Digital Multimeter with Phase Sequence



Features

- Pen type DMM for AC/DC volts PLUS Phase Sequence Indicator
- Non-contact Phase rotation indication
- Phase Sequence Indication with one wire connection
- Frequency (with one wire method), Resistance, Continuity Test, Diode Test
- Data Hold and Auto Power Off
- Carry bag and test leads included
- CAT IV, 600 V

Specifications

TRMS	yes
Voltage AC	1.5 V - 600 V
AC Voltage Accuracy	±1.5 % rdg ±5 digits
Voltage DC	1.5 V - 600V
DC Voltage Accuracy	±0.8 % rdg ±1 digit
Frequency	40 - 69 Hz
Frequency Accuracy	±0.5 % rdg ±1 digit
Resistance	1 Ω - 1500 Ω
Resistance Accuracy	±1.0 % rdg ±5 digits
Continuity Test	yes
Phase Sequence	yes
Data Hold	yes
Auto Power Off	yes
Power Supply	2 x 1.5 V AAA batteries
Battery Life	approx. 170 hours
Display	3¾ Digit LCD
Safety	IEC/EN 61010-1
Measuring Category	Cat IV, 600 V
Size / Weight	250 x 51 x 30 mm / 150 g



TIF 225

Pen Type Digital Multimeter



TIF 225

Features

- Pen type DMM for AC/DC volts
- Frequency, Resistance and Continuity Test
- Data Hold, Relative Measurement and Auto Power Off
- Carry bag and test leads included
- CAT IV, 600 V

Specifications

Voltage AC	1 mV - 600 V
AC Accuracy	±1.0 % rdg ±2 digits
Voltage DC	0.1 mV - 600 V
DC Accuracy	±0.8 % rdg ±1 digit
Frequency	0.01 Hz - 9.999 kHz
Frequency Accuracy	±0.8 % rdg ±2 digits
Resistance	0.1 Ω - 40 MΩ
Resistance Accuracy	±1.0 % rdg ±3 digits
Continuity Test	yes
Diode Test	yes
Data Hold	yes
Relative Measurement	yes
Auto Power Off	yes
Power Supply	2 x 1.5 V AAA batteries
Battery Life	approx. 170 hours
Display	3¾ Digit LCD
Safety	IEC/EN 61010-1
Measuring Category	Cat IV, 600 V
Size / Weight	250 x 51 x 30 mm / 150 g



TIF 275

Professional Digital Multimeter



TIF 275

Features

- Basic Digital Multimeter for AC & DC volts and current
- Also includes Resistance, Frequency, Diode Test, Capacitance, Duty Cycle and Temperature with accessory probes
- Auto Blocking system prevents incorrect connections
- Data Hold, Bargraph, MIN/MAX & Auto Power Off features included
- Integrated rubber holster and stand
- CAT IV, 600 V

Specifications

Voltage AC	1 mV - 1000 V
AC Accuracy	±0.75 %rdg ±2 digits
Voltage DC	0.01 mV - 1000 V
DC Accuracy	±0.25 % rdg ±1 digit
Current AC	0.1µA - 10A
Current DC	1 µA - 10A
Current Accuracy	±1.5 %rdg ±2 digits
Frequency	0.1 Hz - 100 kHz
Frequency Accuracy	±0.5 % rdg ±1 digit
Resistance	0.01 Ω - 30 MΩ
Resistance Accuracy	±0.5 % rdg ±3 digits
Continuity Test	yes
Capacitance	0.01 nF - 30 µF
Diode Test	yes
Temperature	-200 - 850 °C with optional temperature probe
Duty Cycle	2 - 98 %
Data Hold	yes
Bargraph	yes
MAX/MIN readings	yes
Auto Power Off	yes
Power Supply	1 x 9 V battery
Battery Life	max. 200 hours
Display	4 Digit LCD
Safety	IEC/EN 61010-1
Measuring Category	Cat IV, 600 V Cat III, 1000 V
Size / Weight	195 x 84 x 95 mm / 350 g



TIF 130

Pen Phase Sequence Indicator and Voltsensor



TIF 130

Features

- Non-contact Voltage Detection
- Non-contact Phase Sequence Indication, with Green/Red LED
- Pocket clip included
- Battery Life >9000 tests
- CAT IV, 1000 V

Specifications

Voltage AC	100 - 1000 V
Non-Contact Voltage	yes
Phase Sequence	yes
Auto Power Off	yes
Power Supply	2 x 1.5 V AAA batteries
Battery Life	>9000 Tests
Display	LED red/green
Safety	IEC/EN 61010-1
Measuring Category	Cat IV, 1000 V
Size / Weight	160 x 26 x 20 mm / 48 g



TIF 900

Insulation Tester



TIF 900

Features

- Insulation Tests up to 4GΩ with test voltages of 250, 500 or 1000 V
- DMM features, AC/DC volts, Continuity test and Resistance
- LOCK feature for continuous measurements
- Programmable Timer
- Bargraph and Backlight
- Auto Power Off

Specifications

Voltage AC	0.1 - 600.0 V
AC Accuracy	±0.8 % rdg ±4 digits
Voltage DC	0.1 - 600.0 V
DC Accuracy	±0.5 % rdg ±1 digit
Resistance	0.01 - 19.99 Ω
Resistance Accuracy	±2.0 % rdg ±3 digits
Continuity Test	yes
Insulation Resistance	250, 500, 1000 V ranges; up to 4 GΩ
Data Hold	yes
Bargraph	yes
Backlight	yes
Auto Power Off	yes
Power Supply	4 x 1.5 V AA batteries
Battery Life	50 hours
Display	4 Digit LCD
Safety	IEC/EN 61010-1
Measuring Category	Cat III, 550 V
Size / Weight	240 x 100 x 45 mm / 450 g



TIF 7201

Pocket IR Thermometer



Mini infrared thermometer is lightning fast and precise. Measures even small objects. After the measurement the current value and the maximum value are automatically stored and displayed.

Features

- System-on-a-Chip SoC technology: compact and lightweight
- Backlit LCD display w/ dual readings
- °C / °F Switch and MAX function
- Auto power off after 15 sec.
- Battery level indication
- Distance to spot (D/S): 1:1.

Specifications

Temperature measurement range	-33 °C to +220 °C (-27 °F to +428 °F)
Distance to Spot	1:1 optical
Resolution	0.1 °C/°F
Emissivity setting	0,95 fixed
Accuracy	±2 % of reading or ±0 °C (4 °F)
Operating temperature range	-10 °C to +50 °C (14 °F to +122 °F)
Battery Life	Typical 25 hours / Min. 20 hours continuous use
Battery	CR2032 lithium cell battery
Standard Accessories	Batteries
Size / Weight	35 x 100 x 25 mm / 40 g

Distance to spot (D/S): 1:1

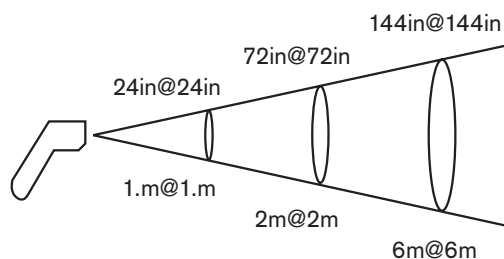

TIF 7612

IR Thermometer PRO with Laser Pointer, 12:1 ratio



Instant contactless temperature measurements using advanced infrared technology.

Features

- SoC (System-on-a-Chip) Technology – Complete IR design incorporated on a single chip, creating compact and lightweight unit
- Innovative optical lens – high accuracy measurements over wide temperature ranges
- 12:1 Distance to Spot (D:S) ratio
- Laser pointer – Simply point at desired target and press the trigger for temperature reading
- External temperature port can extend the temperature measuring range to 1400 °C/1999 °F
- High and low pass filters with audible alarms for out of range measurements
- Temperature modes - Maximum (MAX), Minimum (MIN), Difference (DIF), & Average (AVG)
- Visual low battery indicators; requires two "AAA" batteries

Applications

Check temperature of high voltage equipment and transformers from a safe distance. Detect heating of problem fuses, wires, insulators, connectors, splices, switches, neutrals or overloaded motors due to possible Harmonic currents.

Distance (D) to Spot size (S)

D:S = 12:1

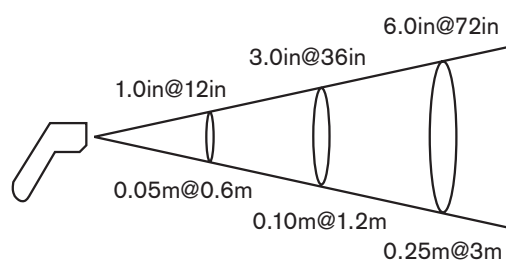

Specifications

Temperature Measurement Range	-60 °C to +500 °C (-76 °F to +932 °F)
Distance:Spot	12:1
Resolution	0,1 °C / 0,1 °F (1° below 9,9 °C and above 199,9 °C)
Emissivity	Adjustable
High and Low temperature alarms	yes
Thermocouple Measurement Range	-64 °C to +1400 °C (-83.2 °F to +1999 °F)
Accuracy	±2 % of reading or 2 °C (4 °F)
Response Time (90%)	0,5 sec
Batterie Life	appr. 18 hours
Batteries	2 x 1,5 V batteries (AAA)
Standard Accessories	Including batteries, thermocouple and protective case
Size / Weight	175,2 x 39,0 x 71,9 mm / 179 g



TIF 7620

IR Thermometer PRO with Laser Pointer, 20:1 ratio



TIF 7620

Instant contactless temperature measurements using advanced infrared technology.

Features

- SoC (System-on-a-Chip) Technology – Complete IR design incorporated on a single chip, creating compact and lightweight unit.
- Innovative optical lens – high accuracy measurements over wide temperature ranges.
- 20:1 Distance to Spot (D:S) ratio
- Laser pointer – Simply point at desired target and press the trigger for temperature reading.
- External temperature port can extend the temperature measuring range to 1400 °C/1999 °F.
- High and low pass filters with audible alarms for out of range measurements.
- Temperature modes - Maximum (MAX), Minimum (MIN), Difference (DIF), & Average (AVG).
- Visual low battery indicators; requires two "AAA" batteries.

Applications

Check temperature of high voltage equipment and transformers from a safe distance. Detect heating of problem fuses, wires, insulators, connectors, splices, switches, neutrals or overloaded motors due to possible Harmonic currents.

Distance (D) to Spot size (S) D:S = 20:1

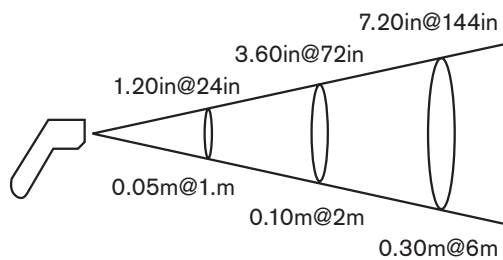

Specifications

Temperature Measurement Range	-60 °C to +760 °C (-76 °F to +1400 °F)
Distance:Spot	20:1
Resolution	0,1 °C / 0,1 °F (1° below 9,9 °C and above 199,9 °C)
Emissivity	Adjustable
High and Low temperature alarms	yes
Thermocouple Measurement Range	-64 °C to +1400 °C (-83.2 °F to +1999 °F)
Accuracy	±2 % of reading or 2 °C (4 °F)
Response Time (90%)	0,5 sec
Batterie Life	appr. 18 hours
Batteries	2 x 1,5 V batteries (AAA)
Standard Accessories	Including batteries, thermocouple and protective case
Size / Weight	175,2 x 39,0 x 71,9 mm / 179 g



ATP-T1

Type K Thermocouple Digital Thermometer T1, T2, ΔT selection



ATP-T1

Features

- Typ K thermocouple
- °C / °F selection
- T1, T2, ΔT selection
- Data hold function
- Min / Max
- Water resistance (IEC 529 - IPX 3)
- Low Battery indication
- Auto Power off selection

Specifications

Input	Dual Type K Thermocouples
Temperature Measurement Range	-58 °F to 2462 °F (-50 °C to 1350 °C)
Resolution	0.1 °F / °C : Up to 999.9 °F / °C 0.1 °F / °C : above 1000 °F / °C
Display	4 digits, 9999 counts
Accuracy	± 3 °F (± 1.6 °C) : -58 °F to 32 °F (-50 °C to 0 °C) ± 0.3 % rdg + 1.8 °F : 32 °F to 1100 °F (0 °C to 600 °C) ± 0.4 % rdg + 1.8 °F : 1100 °F to 2462 °F (600 °C to 1350 °C)
Accuracy after ice-bucket calibration	± 1 °F : 30 °F to 120 °F (-1 °C to 49 °C)
Update Rate	2.5 times / second
Battery	Alkaline 9 V
Size	34 x 144 x 70 mm with Boot : 40 x 153 x 77 mm
Weight	(with Boot) 285 g
Ambient Operating Temperature	0 °C to 50 °C (32 °F to 120 °F)
Storage Temperature	-25 °C to 70 °C (-13 °F to 158 °F) without battery
Relative Humidity	10 % to 95 % RH non-condensing
Standard Accessories	Battery, Two K-type Thermocouples, Boot, Case

Optional Accessories

ATP STP160	PT Temperature
TPK-56	Replacement Type K thermocouple



RA 43230

Swivel-Head Digital Thermometer

ROBINAIR®

Features

- Head swivels 180° – easy to see at any angle
- Compact size – convenient to carry & store
- Selectable – Celsius and Fahrenheit
- Reliable readings over entire range
- For surface, liquid and air temperatures
- Protective sheath with pocket clip

Specifications

Temperature Range	-50 °C to 150 °C (-58 °F to 302 °F)
Accuracy	± 1 °C between -20 °C and 120 °C (otherwise ± 2 °C or ± 4 °F) ± 2 °F between - 4 °F and 248 °F
Display Resolution	0,1° between - 19,9 and 199,9 otherwise 1°
Auto Power off	After 10 minutes
Battery	1,5 Volt, size LR44

RA 43240

Digital Thermometer

ROBINAIR®

Features

- Rugged stainless steel needle probe
- Durable case includes a cover to protect the probe
- Temperature measurements in °C or °F
-40 °C to + 200 °C / -40 °F to + 390 °F
- DATA HOLD
- Water resistant
- Shock proof
- Auto power off after 3 minutes

TIF 3110

IR-Thermometer/Psychrometer



TIF 3110

The new TIF3110 IR Thermometer/Psychrometer combines the function of a humidity meter, type-K thermocouple thermometer, and an infrared thermometer into one convenient handheld device. Ideal for quickly checking indoor air quality in offices, production rooms or in warehouses.

Features

- Built in Infrared thermometer for non-contact temperature measurement to 500 °C with a 30:1 distance to spot ratio
- Type K temperature input for contact temperature measurement to 1370 °C
- Display air temperature, relative humidity, dew point and wet bulb temperatures
- Highly accurate and dependable readings – within 2 % RH
- Rugged design that is easy to grip and hold
- Large easy to view LCD is easy to read from a distance
- Rugged carrying case

Specifications

Temperature (Type-K)	-200 °C to 1370 °C +/- 1%
Temperature (IR)	-50 °C to 500 °C +/- 2%
Humidity	10 to 90% RH (Relative Humidity)
Wet Bulb	-21 °C to 60 °C
Dew Point	-68 °C to 60 °C
Resolution	0.1°/ 1° and 0.1 % RH (Relative Humidity)
Size / Weight	200 x 74 x 48 mm / 278 g

CE



TIF 3420

Differential Pressure Meter



TIF 3420

The TIF3420 easily takes differential pressure readings with the dual input pressure manometer. Use to measure differential, absolute and static pressures in most HVAC systems.

Features

- Chose the units of measure you are most comfortable with – 11 selectable units of measure to choose from
- Store MIN/MAX and AVG readings
- Rugged design that is easy to grip and hold
- Large easy to view LCD is easy to read from a distance
- Zero function lets you correct for any offsets in readings or measurements

Specifications

Pressure Range	to 138 mBar
Resolution	0,1 mbar
Accuracy	± 0.3 % FS
Max. Pressure	689 mbar
Size / Weight	200 x 74 x 48 mm / 278 g



TIF 3310

Dual Input Thermocouple Thermometer



TIF 3310

The TIF3310 easily takes differential temperature readings with the dual type-K thermocouple probes.

Features

- Use contact differential temperature measurements (T1-T2) to display HVAC Superheat measurements
- Display temperature differentials between probes
- Rugged design that is easy to grip and hold
- Large easy to view LCD is easy to read from a distance
- Store MIN/MAX and AVG readings
- Includes 2 bead type wire temp probes, rugged carrying case, and 9 V battery

Specifications

Temperature (Type-K)	-200 °C to 1370 °C
Resolution	0.1 °C / 1 °C
Operating Temperature	0 °C to 50 °C
Size / Weight	200 x 74 x 48 mm / 278 g



TIF 3220

Thermo-Anemometer and IR Thermometer



TIF 3220

The new TIF3220 measures air speed and temperature. It is ideal for spot air flow measurements at various air returns and vents.

Features

- Simultaneously display both air flow or air velocity and ambient temperature measurements
- Easy to set area dimensions that can be stored in the meters internal memory and recalled during the next use of the instrument
- Built in Infrared thermometer for non-contact temperature measurement to 500°C with a 30:1 distance to spot ratio
- Rugged design that is easy to grip and hold
- Large easy to view LCD is easy to read from a distance
- Store MIN and MAX readings. Hold specific readings with the data hold function
- Cable connects the vane sensor to the instrument making it easy to reach ceiling vents

Specifications

Air Flow	0,40 – 30,00 Meters/sec
	80 – 5900 ft/min
	1,4 – 108,0 km/h
	0,9 – 67,0 MPH
	0,8 – 58,0 Knots
Distance to Spot Ratio	30:1
Temperature (IR)	-50 °C to 500 °C
Ambient Temperature	-10 °C to 60 °C
Size / Weight	200 x 74 x 48 mm / 278 g



TIF 3340

4-Channel Differential and Infrared Thermometer T1, T2, T3, T4 and IR



TIF 3340

Features

- 4-Channel Differential Thermometer
- Infrared Thermometer for non-contact surface measurements
- Multiple Readings
- Differential Readings to display Superheat
- MIN/MAX/AVG readings with DATA HOLD
- Large Display

Specifications

Temperature (Typ K)	-200 °C to 1370 °C
Temperature (IR)	-30 °C to 550 °C
Resolution	0,1 °C / 1,0 °C
Accuracy (Typ K)	1 °C (> -100 °C)
Accuracy (IR)	2 °C (> -10 °C)
T1 - T2, T3 - T4	±0,5 % +1 °C



RA 75240

Refractometer

ROBINAIR®

RA 75240

Features

- Used for measuring freezing point of Propylene Glycol or Ethylene Glycol based coolants
- Also can be used for electrolytic solutions found in batteries
- Precision instrument with High quality optics and ultra smooth focusing
- Range from 0 °C to -76 °C (32 °F to -60 °F)
- Includes storage case, pipettes and calibration screwdriver

IPC-307

Inverter Phase Checker



IPC-307

L1 - L2 - L3

An intelligent and easy to use diagnostic tool for problem solving in Inverter driven Air Conditioning and Refrigeration systems. The Inverter Phase Checker will pinpoint the specific cause of problems by measuring and analyzing the output sequence from the inverter control board, providing a clear indication of the correct operation.

Features

- Compatible with all makes of system
- Small and Portable
- Simple and quick connections
- Magnetic mounting for hands free testing
- Super bright LEDs for use in sunlight
- Audible indications of test activity and completion
- Memory feature stores test results for instant recall
- Test leads with shrouded safety protectors for interchangeable probe connectors (alligator clip included)

CE

RG 6-E PARTS LIST

Recovery Unit RG 6-E Parts List

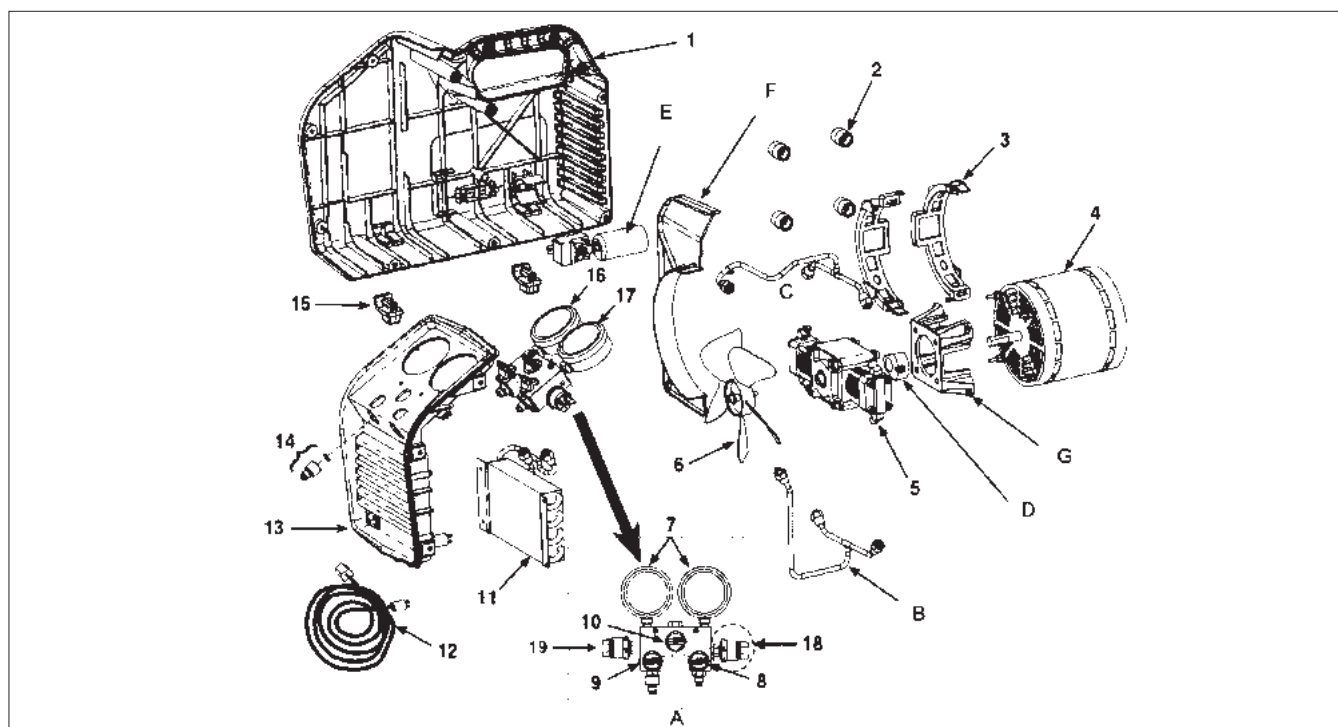

Item	Description	Part Number
1	Plastic case (left)	550495
	Plastic case (right)	550496
2	Mounting Bushings	550503
3	Mounting brackets	SK-6021
4	Motor-Kit 230 V (motor, relay, capacitor, hardware)	SK-6018
5	Compressor Assy.	568114-E
6	Fan Kit	SK-6008
7	Gauge lens	GA1000
8	Red knob	100124
9	Blue knob	100123
10	Black knob	100122
11	Condensor Kit	SK-6014
12	Power Cord	135-200341-001
13	Front Panel Assy. (incl. switches, circuit breaker, hardware)	SK-6019-E
14	Filter Inlet Repl. Kit	SK-6001
15	Rubber Foot (each)	550502
16	Low Side Gauge	SK-6003
17	High Side Gauge	SK-6022
18	High Pressure Switch	549259
19	Low Pressure switch	113726

Item	Description	Part Number
A	Complete Manifold Assy. (manifold, fittings, valves, knobs, pressure sensors and gauges)	SK-6016-E
B	Lower Tubing Assy.	550076
C	Upper Tubing Assy.	110-201490-001
D	Coupler	551917-KIT
E	Run Capacitor (30mF) Start Capacitor (177mF)	556593
F	Plastic Insert, Right	550500
	Plastic Insert, Left	550501
G	Molded Compressor Mount	549758

Replacement Kits & Accessories

Part Number	Description
SK-6006	Compressor Rebuild Kit
SK-6015	Piston Seal Rebuild Kit
SK-6007	Valve Replacement Kit
100343	Filter/Drier
100345	Filter hose

RG 5410A-E PARTS LIST

Recovery Unitt RG 5410A-E Parts List

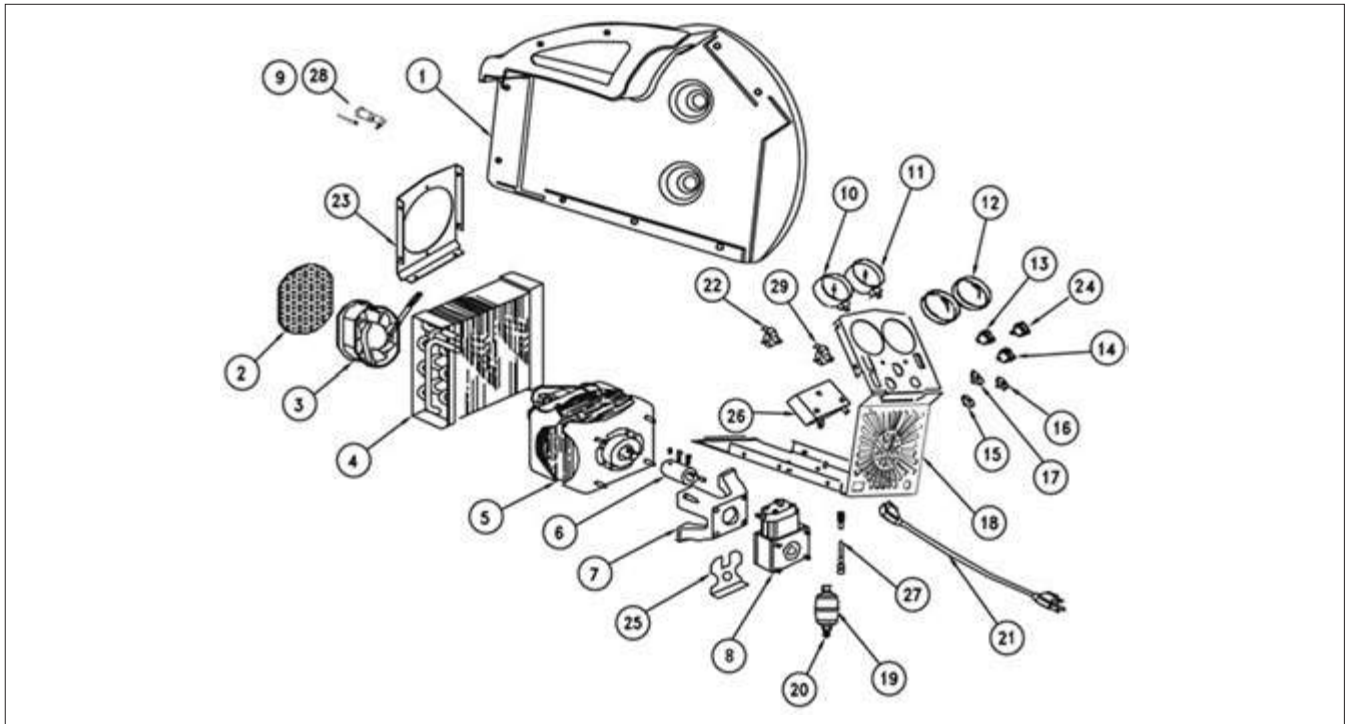

Item	Description	Part Number
1	Plastic case	100134 L&R
2	Fan grill	100505
3	Axial fan	EL1818
4	Condenser	CD1201
5	Motor	EL1822
6	Coupler	CP1315
7	Bell housing	CP1001
8	Compressor	CP1320
9	Fuse - 5x20mm	100406
10	Blue Gauge (Low Side)	GA1500
11	Red Gauge (High Side)	GA0800
12	Gauge lens	GA1000
13	On/Off switch	EL1310
14	Start switch	EL1309

Item	Description	Part Number
15	Blue knob	100123
16	Red knob	100124
17	Black knob	100122
18	Front panel	110-200395-001
19	Filter	100343
20	Flare cap	NB6501
21	Powercord	135-200341-001
22	High Pressure switch	EL2802
23	Rear panel	100318
24	Select Switch	105-200396-001
25	Compressor Bracket	100207
26	Manifold	700009
27	Hose 4"	100345
28	Fuse holder	100419
29	VAC Sensor	113726

Replacement Kits & Accessories

Part Number	Description
KT3302	Piston seal replacement (middle section of compressor)
KT3303	Valve replacement kit (top section of compressor)
KT3307	Compressor repair kit (all three sections of compressor)
KT3308	Shaft replacement kit (bottom section of compressor)
RGT30NS	13.6 kg (30 lbs) recovery tank, 24.1 bar (350 psi) working pressure
RGT50NS	22.7 kg (50 lbs) recovery tank, 24.1 bar (350 psi) working Pressure

MINIMAX-E PARTS LIST

Recovery Unit MINIMAX-E Parts List

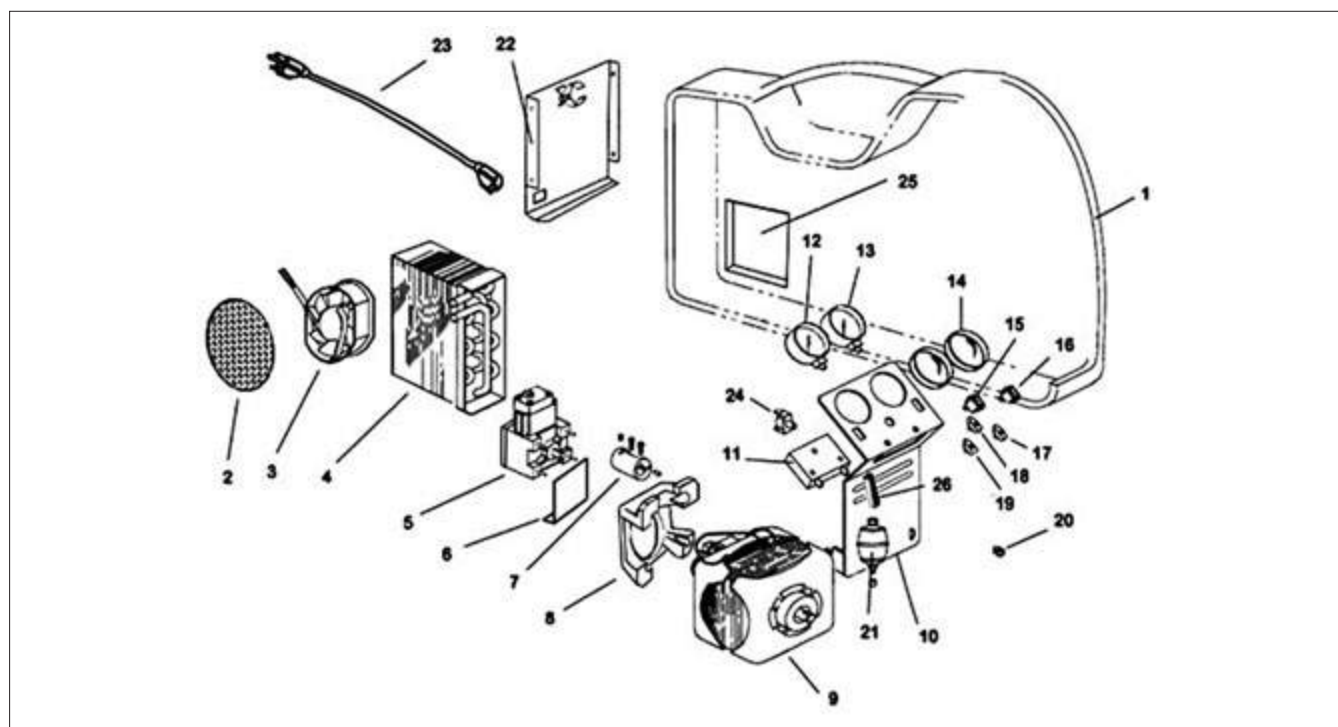

Item	Description	Part Number
1	Plastic case	100118
2	Fan grill	100179
3	Axial fan	100242
4	Condenser	100139
5	Compressor	CP1320
6	Compressorbracket	100207
7	Coupler	CP1315
8	Bell housing	CP1001
9	Motor	EL1822
10	Frontpanel	100121
11	Manifold	700009
12	Blue Gauge (Low Side)	GA1500
13	Red Gauge (High Side)	GA0800
14	Gauge lens	GA1000

Item	Description	Part Number
15	ON/OFF switch	EL1310
16	Starts switch	EL1309
17	Red knob	100124
18	Black knob	100122
19	Blue knob	100123
20	Flare cap	NB6501
21	Filter	100343
22	Rear panel	105-200430-001
23	Powercord	135-200341-001
24	Pressure switch	EL2802
25	Fan grill inlet	100180
26	Filterconnector	100345

Replacement Kits & Accessories

Part Number	Description
KT3302	Piston seal replacement (middle section of compressor)
KT3303	Valve replacement kit (top section of compressor)
KT3307	Compressor repair kit (all three sections of compressor)
KT3308	Shaft replacement kit (bottom section of compressor)
RGT30NS	13.6 kg (30 lbs) recovery tank, 24.1 bar (350 psi) working pressure
RGT50NS	22.7 kg (50 lbs) recovery tank, 24.1 bar (350 psi) working Pressure



RG 3000-E PARTS LIST

Refrigerant Recovery Unit Parts List

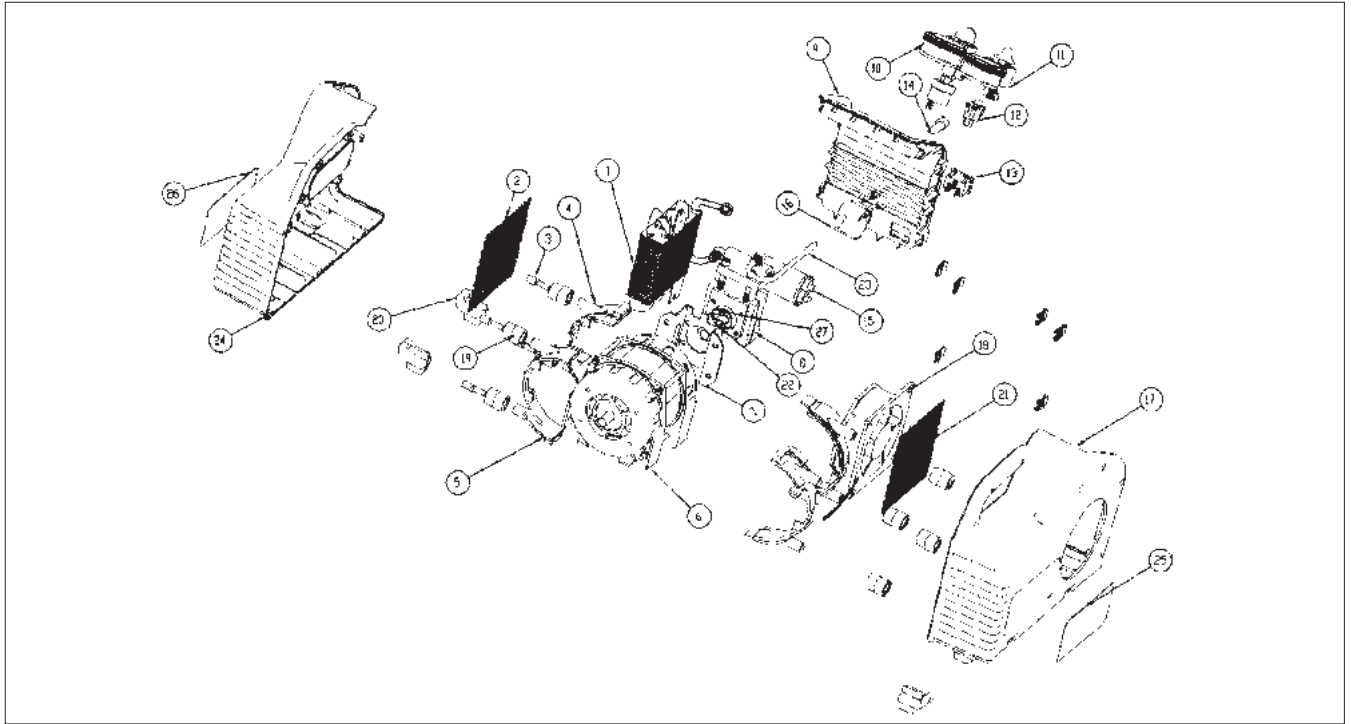

Item	Description	Part Number
1	Condensor	105-201234-001
2	Condensor grill	110-ATP100179
3	Mounting bushing (8 pieces)	111-ATP552732
4	Mounting Supports Left	111-201229-001
5	Mounting Supports Right	111-201230-001
6	Motor 230 V / 50 Hz	145-201231-001
7	Compressor Mount	110-201212-001
8	Compressor	105-201221-001
9	Front Panel	111-201200-001
10	High Side Gauge including Valve	105-201232-001
11	Low Side Gauge including Valve	105-201233-001
	High Side Gauge	110-201201-001
	Low Side Gauge	110-201202-001
12	ON/OFF Switch	145-ATPEL1310

Item	Description	Part Number
13	Power Connection	140-ATPRR121917
14	Fuse Holder	111-ATP100419
15	Capacitor	125-201226-001
16	Capacitor Mount	111-201241-001
17	Plastic Case (right)	111-201228-001
18	Fan 230 V / 50 Hz	145-201235-001
19	Mounting Bracket (8 pieces)	111-ATP550503
20	Rubber Foot (4 pieces)	111-ATP550502
21	Fan Grill	110-201243-001
22	Coupler	110-201213-001
23	Inlet Tube	110-201242-001
24	Plastic Case (left)	111-201227-001
25	Label Operating Instruction	180-201239-001
26	Unit Identification Label	180-201239-001
27	Coupler Screw	114-ATPNB3204

ROBINAIR VACUUM PUMPS PARTS LIST

Cooltech™ Vacuum Pumps Parts List for Models: 15121A, 15401, 15601

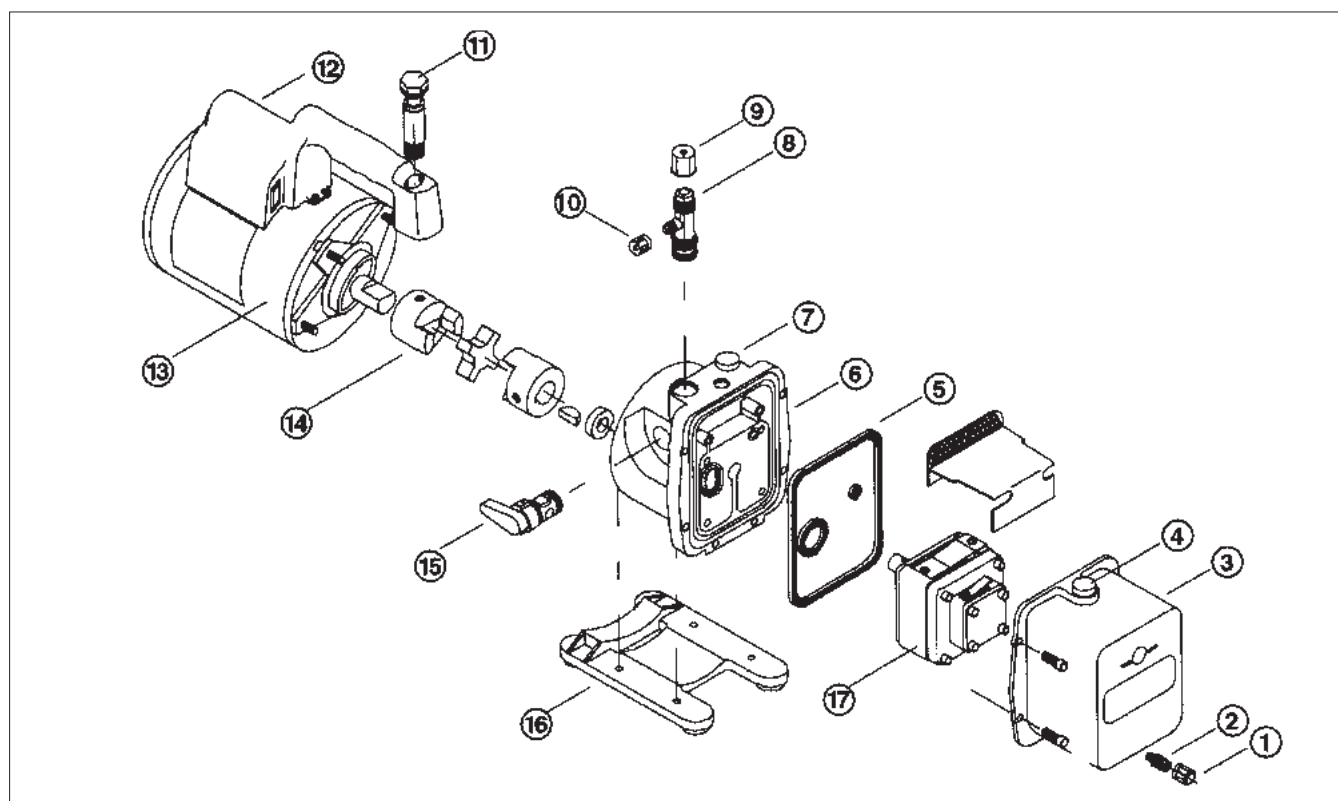

Item	Description	Part Number
1	Oil Drain Cap (6)	RA 40572
3	Module Cover Kit (includes No. 1, 2, 4, 5)	RA 15337
4	Oil Fill Cap	RA 15371
8	Intake Fitting (includes No. 9, 10)	RA 15364
11	Vent Bolt (includes O-Rings)	RA 15338
12	Handle, Power Cord and Switch Assembly (230 V)	RA 15466
13	Motor for RA 15401 (115 V / 230 V)	RA 116214
13	Motor for RA 15601 (115 V / 230 V)	RA 116214
13	Motor for RA 15121A (115 V / 230 V)	RA 118638

Item	Description	Part Number
14	Coupling	RA 13192
15	Iso-Valve™ Assembly	RA 15368
16	Base and Foot Assembly	RA 15369
17	Pump Assembly, less motor (incl. 3 & 6) for RA 15401	RA 15547
17	Pump Assembly, less motor (incl. 3 & 6) for RA 15601	RA 15548
17	Pump Assembly, less motor (incl. 3 & 6) for RA 15121A	RA 15144
--	Seal Replacement Kit (not show)	RA 15367
--	Filter (only RA 15121A)	RA 15147

PARTS LIST RA 15301-E · RA 15501-E

VacuMaster™ Vacuum Pump

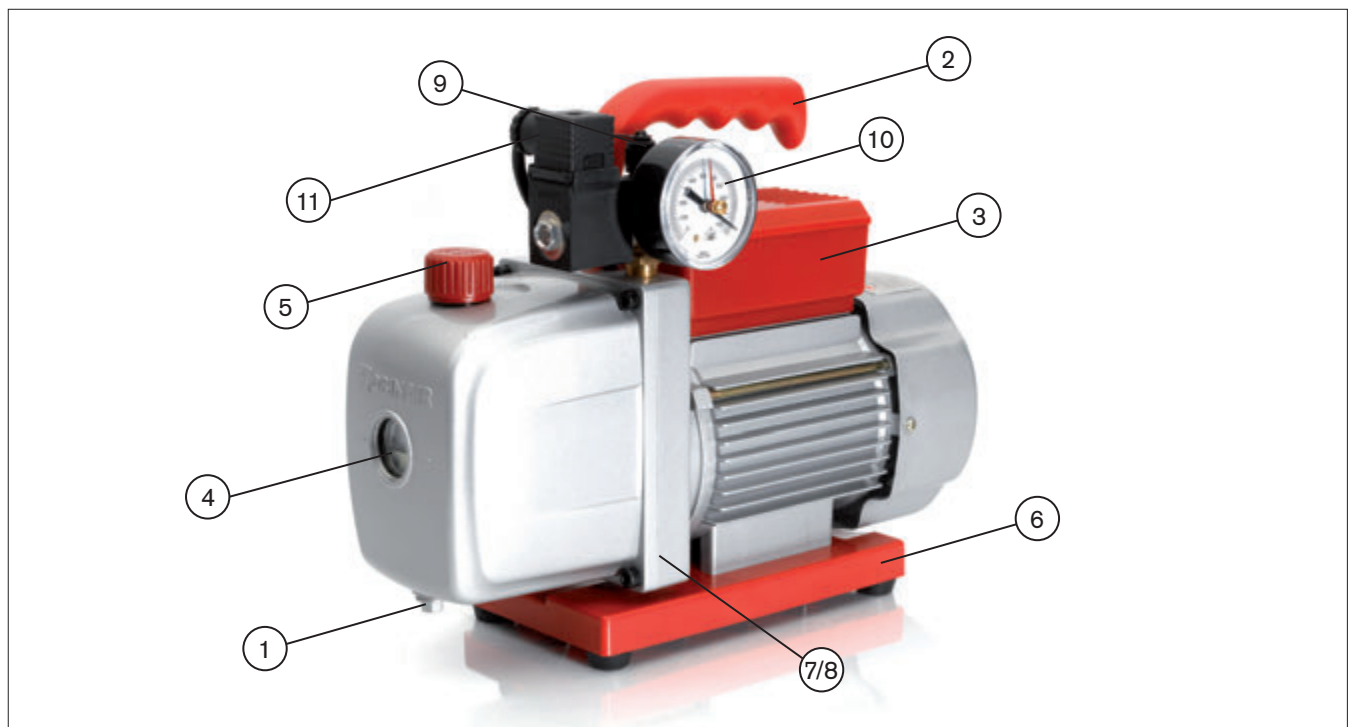

Item	Description	Part Number
1	Oil Drain Fitting	550101
2	Handle	550102
3	Electrical box with Capacitor, IEC connector and switch for model RA 15301-E	550103
4	Sight Glass oil-level	unavailable
5	Oil Fill / Exhaust Fitting	550105
6	Base	550106
7	Housing Gasket for model RA 15301-E	550107
8	Housing Gasket for model RA 15501-E	550108
9	Inlet Adapter, 1/4" FFL x 3/8" MFL	550109
10	Vacuum Gauge	550110
11	Solenoid Valve Assembly	550111

TIF REPLACEMENT PARTS

Refrigerant Leak Detector Replacement Sensor Tips and Filters



TIF 555

**Maintenance Kit
(3 Sensing Tips and
3 Tip Protectors)**

Used on:
TIF 5550
TIF 5550A
TIF 5650
TIF 5650A
TIF 5750
TIF 5750A
TIF H10A



TIF ZX-14

**Replacement Kit
(Filter, "O"-Ring (2)
and Tip)**

Used on:
TIF ZX-1E
ATP ZX-1A



TIF XP-2

**Maintenance Kit
(3 Sensing Tips and
3 Tip Protectors)**

Used on:
TIF XL-1
TIF XL-1A
TIF RX-1
TIF RX-1A
TIF XP-1
TIF XP-1A



TIF ZX-15

Filter cartridge

Used on:
TIF ZX-1E
ATP ZX-1A

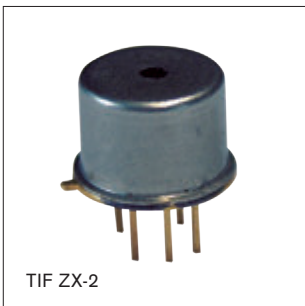

TIF ZX-2

**Replacement Heated
Pentode™ Sensor**

Used on:
TIF ZX-1E
ATP ZX-1A



Pressure Temperature Guide – SI

Saturated Conditions – Pressure (kPa)

Temp. °C	R22	R134a	R404A	R410A	R507	Temp. °F
-40	105	51	135	176	139	-40
-39	110	54	141	184	145	-38
-38	115	57	148	192	152	-36
-37	121	60	155	201	158	-35
-36	126	63	161	210	165	-33
-35	132	66	169	219	173	-31
-34	138	70	176	229	180	-29
-33	144	73	183	238	188	-27
-32	151	77	191	249	196	-26
-31	157	80	199	259	204	-24
-30	164	84	208	270	213	-22
-29	171	88	216	282	222	-20
-28	178	93	225	293	231	-18
-27	186	97	235	305	240	-17
-26	193	102	244	318	250	-15
-25	201	106	254	331	260	-13
-24	210	111	264	344	270	-11
-23	218	116	274	357	281	-9
-22	227	122	285	371	292	-8
-21	236	127	296	386	303	-6
-20	245	133	307	401	315	-4
-19	255	139	319	416	326	-2
-18	265	145	331	432	339	0
-17	275	151	343	448	351	1
-16	285	157	356	465	364	3
-15	296	164	369	482	377	5
-14	307	171	382	499	391	7
-13	319	178	396	517	405	9
-12	330	185	410	536	420	10
-11	342	193	424	555	434	12
-10	355	201	439	575	450	14
-9	367	209	454	595	465	16
-8	381	217	470	615	481	18
-7	394	225	486	637	498	19
-6	408	234	503	658	514	21
-5	422	243	519	681	532	23
-4	436	253	537	703	549	25
-3	451	262	554	727	567	27
-2	466	272	573	751	586	28
-1	482	282	591	775	605	30
0	498	293	610	801	624	32
1	514	304	630	827	644	34
2	531	315	650	853	665	36
3	548	326	670	880	686	37
4	566	338	691	908	707	39
5	584	350	712	936	729	41
6	603	362	734	965	751	43
7	622	375	757	995	774	45
8	641	388	780	1.025	798	46
9	661	401	803	1.057	822	48
10	681	415	827	1.088	846	50
11	702	429	852	1.121	871	52
12	723	443	877	1.154	897	54
13	745	458	902	1.188	923	55
14	767	473	928	1.223	949	57

Saturated Conditions – Pressure (kPa)

Temp. °C	R22	R134a	R404A	R410A	R507	Temp. °F
15	789	488	955	1.258	977	59
16	812	504	982	1.295	1.005	61
17	836	521	1.010	1.332	1.033	63
18	860	537	1.039	1.370	1.062	64
19	885	554	1.068	1.408	1.092	66
20	910	572	1.097	1.448	1.122	68
21	936	590	1.127	1.448	1.153	70
22	962	608	1.158	1.529	1.184	72
23	989	627	1.190	1.571	1.216	73
24	1.016	646	1.222	1.614	1.249	75
25	1.044	665	1.255	1.657	1.283	77
26	1.072	685	1.288	1.702	1.317	79
27	1.101	706	1.322	1.748	1.352	81
28	1.131	727	1.357	1.794	1.387	82
29	1.161	748	1.392	1.841	1.423	84
30	1.192	770	1.428	1.889	1.460	86
31	1.223	793	1.465	1.939	1.498	88
32	1.255	815	1.503	1.989	1.536	90
33	1.288	839	1.541	2.040	1.575	91
34	1.321	863	1.580	2.092	1.615	93
35	1.355	887	1.620	2.145	1.655	95
36	1.389	912	1.660	2.199	1.697	97
37	1.424	937	1.701	2.254	1.739	99
38	1.460	963	1.743	2.310	1.782	100
39	1.497	990	1.786	2.367	1.825	102
40	1.534	1.017	1.829	2.426	1.870	104
41	1.571	1.044	1.874	2.485	1.915	106
42	1.610	1.072	1.919	2.545	1.961	108
43	1.649	1.101	1.965	2.607	2.008	109
44	1.689	1.130	2.012	2.670	2.056	111
45	1.729	1.160	2.059	2.734	2.104	113
46	1.770	1.190	2.108	2.799	2.154	115
47	1.812	1.221	2.157	2.865	2.204	117
48	1.855	1.253	2.207	2.932	2.256	118
49	1.899	1.285	2.259	3.001	2.308	120
50	1.943	1.318	2.311	3.071	2.361	122
51	1.988	1.351	2.364	3.142	2.415	124
52	2.033	1.385	2.418	3.214	2.471	126
53	2.080	1.420	2.472	3.288	2.527	127
54	2.127	1.456	2.528	3.363	2.584	129
55	2.175	1.492	2.585	3.439	2.642	131
56	2.224	1.528	2.643	3.517	2.701	133
57	2.274	1.566	2.702	3.596	2.761	135
58	2.324	1.604	2.762	3.676	2.823	136
59	2.375	1.642	2.823	3.758	2.885	138
60	2.428	1.682	2.885	3.842	2.949	140
61	2.481	1.722	2.948	3.927	3.013	142
62	2.534	1.763	3.012	4.013	3.079	144
63	2.589	1.804	3.078	4.101	3.147	145
64	2.645	1.847	3.145	4.191	3.215	147
65	2.701	1.890	3.213	4.282	3.285	149

Kindly supported by DuPont.

Temperature units

Temperature in °C	Temperature in °F
100 °C	212 °F
96 °C	205 °F
90 °C	194 °F
80 °C	176 °F
70 °C	158 °F
60 °C	140 °F
55 °C	122 °F
40 °C	104 °F
30 °C	86 °F
27 °C	80 °F
24 °C	76 °F
22 °C	72 °F
21 °C	69 °F
18 °C	64 °F
15 °C	59 °F
12 °C	53 °F
7 °C	45 °F
0 °C	32 °F
-6 °C	21 °F
-14 °C	6 °F
-30 °C	-24 °F
-37 °C	-35 °F
-51 °C	-60 °F
-57 °C	-70 °F
-68 °C	-90 °F

Conversion factors

	Torr	mbar	bar	Pa	atm
1 Torr =	1	1,33	$1,33 \times 10^{-3}$	133	$1,32 \times 10^{-3}$
1 mbar =	0,750	1	10^{-3}	10^2	$0,987 \times 10^{-3}$
1 bar =	750	10^{-3}	1	10^5	0,987
1 Pa =	$7,5 \times 10^{-3}$	10^{-2}	10^{-5}	1	$0,987 \times 10^{-6}$
1 atm =	760	1013	1,013	$1,01325 \times 10^5$	1



Index

100343	13, 14, 15, 16	278-FSM-15	69	RA 10696	74	RA 31079	40
100345	13, 14, 15, 16	278-FSM-16	69	RA 10778	42	RA 31096	40
100911	14, 15	278-FSM-18	69	RA 11910-E	36	RA 32036	40
102-F-04	64	278-FSM-22	69	RA 11920-E	37	RA 32060	40
102-F-05	64	312-FC	59	RA 13047A	28	RA 32072	40
102-F-06	64	364-FHA-04	64	RA 13119	28	RA 32096	40
102-F-08	64	364-FHA-06	64	RA 13145	75	RA 33036	40
102-F-10	64	364-FHA-08	64	RA 13203	28	RA 33060	40
102-F-12	64	364-FHA-10	64	RA 13204	28	RA 33096	40
124-C	74	364-FHA-12	64	RA 14010A	32	RA 34750	17
125-C	74	364-FHA-14	64	RA 14388	77	RA 40010LP	39
127-C	74	364-FHAM-10	64	RA 14777	32	RA 40020HP	39
127-CO	74	364-FHAM-12	64	RA 15121A	26	RA 40025E	33, 39
16-C	47	364-FHB-04	65	RA 15301-E	27	RA 40082	42
17-C	47	364-FHB-06	65	RA 15401	25, 26	RA 40083	42
174-F	58	364-FHB-08	65	RA 15501-E	27	RA 40084	42
175EX06	67	364-FHBM-10	65	RA 15601	26	RA 40288	75
175EX08	67	364-FHBM-12	65	RA 16257	10	RA 40330	76
175EX10	67	364-FHBM-6	65	RA 16263	10	RA 40336	76
175EX12	67	367-FH	65	RA 16331	10	RA 40352	76
175EX14	67	368-FH	65	RA 16332	10	RA 40384	76
175EX16	67	370-FH	66	RA 16333	10	RA 40386	76
175EX18	67	406-FA	60	RA 16336	10, 12	RA 40390	76
175EX22	67	470-FH	66	RA 16337	10, 12	RA 40396	76
175EX26	67	470-FHC	66	RA 16338	10, 12	RA 40398	76
175EX	67	500-FC	70	RA 16339	10	RA 40399	76
175EXC	67	500-FCM	70	RA 16340	10	RA 40416	76
175EXP	67	525-F	71	RA 16349	10	RA 40418	76
18-C	47	527690RED	9	RA 16353	10, 11	RA 40423	76
193-S	72	93-S-04	72	RA 16356	11	RA 40560A	76
195-FC	68	93-S-06	72	RA 17160	32	RA 40563A	42
206-FB	58	95-S	72	RA 17162	32	RA 40572	77
208-F	73	AC Smart Bender	63	RA 17506	17	RA 410860A	40
210-F	73	ADS-100	21	RA 17800B	17	RA 410A60S	40
23-C	47	ASTRO	52	RA 17801B	17	RA 410Q60S	40
24-C	47	ATP-7038	9	RA 18171	77	RA 41132E150C	34
26-C	47	ATP-C1	8, 35	RA 18180	42	RA 41132E	34
27-C	47	ATP-C2	8	RA 18190A	46	RA 41132E90C	34
270-F-14	67	ATP-T1	89	RA 18191A	46	RA 41132HP	38
270-F-18	67	ATP STP160	89	RA 18403	77	RA 41132LP	38
275-FS	68	ATP ZX-1A	4	RA 18451	42	RA 41138E150C	34
275-FSC	69	Bright Flair	55	RA 18501	42	RA 41138E	34
275-FSM	69	CLK-1	18	RA 18511	42	RA 41138E90C	34
278-FS-03	68	CP1320	14, 15	RA 18512	42	RA 41138HP	38
278-FS-04	68	GALAXY	51	RA 18513	42	RA 41138LP	38
278-FS-05	68	HSG-1000.01S	51	RA 18514	42	RA 41140E	39
278-FS-06	68	IPC-307	96	RA 18561	75	RA 41140P	39
278-FS-08	68	MINIMAX-E	15	RA 18565	75	RA 41140SPK	39
278-FS-10	68	MPS 1	53	RA 19150	46	RA 41148E150C	34
278-FS-12	68	MPS 2	53	RA 19776	17	RA 41148E	34
278-FSM-04	69	MPS 3	53	RA 19885	46	RA 41148HP	38
278-FSM-06	69	PT-109	78	RA 19886	46	RA 41148LP	38
278-FSM-08	69	RA-SVOM-18	78	RA 30036	40	RA 411744-E	35
278-FSM-10	69	RA 1000FS	43	RA 30060	40	RA 411744E300C	35
278-FSM-12	69	RA 1000 Gasket	43	RA 30072	40	RA 411744HP	35
278-FSM-14	69	RA 1000HS	43	RA 31036	40	RA 411744LP	35
		RA 10250	45	RA 31060	40	RA 41178-E	33
		RA 10292	45	RA 31078	40	RA 41178E150C	34

RA 41178E	34	RA 68260A	40	S26883	61	TIF XP-5A	6, 7
RA 41178E90C	34	RA 68272A	40	S32633	61	TIF ZX-10	4
RA 41178HP	38	RA 68296A	40	S38600	68, 69	TIF ZX-11	4
RA 41178LP	38	RA 68336A	40	S74761	58	TIF ZX-14	4
RA 41182E150C	34	RA 68360A	40	S74762	58, 59	TIF ZX-15	4
RA 41182E	34	RA 68372A	40	S74765	58, 59	TIF ZX-20	4
RA 41182E90C	34	RA 68396A	40	S74833	60	TIF ZX-2	4
RA 41182HP	38	RA 69036A	40	S74834	60	TIF ZX-25	4
RA 41182LP	38	RA 69060A	40	S75015	58, 59, 62	TIF ZX-3E	4
RA 41190E	34	RA 69072A	40	S75046	58, 59	TIF ZX-6	4
RA 41190HP	38	RA 69096A	40	S77511	58	TPK-56	89
RA 41190LP	38	RA 70060A	40	S8920073	47		
RA 42024	60	RA 744300	35	SK-6001	13, 14, 15, 16		
RA 42232E150C	34	RA 75240	96	TC-1000	59		
RA 42232E	34	RA 801E	71	TC-1010	59		
RA 42232E90C	34	RA 825GN-50	48	TC-1050-RH	61		
RA 42238E150C	34	RA 825GN-55	48	TC-1050 IMP	61		
RA 42238E	34	RA 825H2-50	50	TC-1550	62		
RA 42238E90C	34	RA 894A	39	TC-1550C	62		
RA 42240E	39	RA 987GN-170	35, 49	TIF 130	84		
RA 42240KBE	39	RA 987Z117ATP	35, 49	TIF 150	80		
RA 42240KBK	39	RA BV 1/4" R	44	TIF 175	79		
RA 42240KRD	39	RA BV 1/4" B	44	TIF 225	82		
RA 42240KYW	39	RA BV 1/4" Y	44	TIF 230	81		
RA 42240P	39	RAFL - 1/2"	56	TIF 275	83		
RA 42240SPK	39	RAFL - 1/4"	56	TIF 3110	91		
RA 42248E150C	34	RAFL - 10 mm	56	TIF 3220	94		
RA 42248E	34	RAFL - 12 mm	56	TIF 3310	93		
RA 42278E150C	34	RAFL - 16 mm	56	TIF 3340	95		
RA 42278E	34	RAFL - 18 mm	56	TIF 3420	92		
RA 42278E90C	34	RAFL - 22 mm	56	TIF 4413-2	79, 80		
RA 42282-E	33	RAFL - 3/4"	56	TIF 7201	86		
RA 42282E150C	34	RAFL - 3/8"	56	TIF 7612	87		
RA 42282E	34	RAFL - 3/8" x 1/4"	56	TIF 7620	88		
RA 42282E90C	34	RAFL - 5/8"	56	TIF 8801	9		
RA 42290E	34	RAFL - 6 mm	56	TIF 8806A	9		
RA 43160-E	33	RAFL - 7/8"	56	TIF 8806B	9		
RA 43160E150C	34	RA H100	50	TIF 8900-E	9		
RA 43160E	34	RA HFO1234yf	46	TIF 9000S	19		
RA 43160E90C	34	RA HPHFO1234yf	46	TIF 900	85		
RA 43180E150C	34	RA LPHFO1234yf	46	TIF 9010A	22		
RA 43180E	34	RA RG0,90-5-4	45	TIF 9030E	20		
RA 43180E90C	34	RA RG180-5-4	45	TIF 9055	24		
RA 43230	90	RA TC10001	57	TIF 9060S	23		
RA 43240	90	RA TC10002	57	TIF IR-10	5		
RA 45500	75	RA TC11	57	TIF IR-11	5		
RA 50396	76	RA TC12	57	TIF IR-12	5		
RA 615N	50	RA VG-1	30	TIF IR-1A	5		
RA 62121	41	RA VG-64	31	TIF IR-2	5		
RA 621N	50	RG 3000-E	16	TIF IR-4	5		
RA 63096	41	RG 5410A-E	14	TIF IR-5	5		
RA 6639-MO	50	RG 6-E	13	TIF IR-7	5		
RA 68060	41	RGT30NS	13	TIF IR-9	5		
RA 68136A	40	RGT30NS	14, 15, 16	TIF RX-1A	7		
RA 68160A	40	RGT50NS	13, 14, 15, 16	TIF TK101	79		
RA 68172A	40	S10000539	78	TIF XP-1A	6		
RA 68196A	40	S1000099	47	TIF XP-2	6, 7		
RA 68236A	40	S16002045	78	TIF XP-4A	6, 7		



PROMAX®



ROBINAIR®

Advanced Test Products · Bosch Automotive Service Solutions GmbH

Lürriper Str. 62 · 41065 Mönchengladbach · Germany

Phone +49 21 61 - 5 99 06-0 · Fax +49 21 61 - 5 99 06-16 · www.atp-europe.de · info@atp-europe.de